

ASSEMBLY MANUAL



ANGEL 2000 GLIDER

“ Graphics and specifications may change without notice “.

MS: 129



ARF

Specifications:

Wingspan-----78.7 in (200cm).

Wing area-----582.8sq.in (37.6sq.dm).

Weight-----2.4lbs (1.1 kg).

Length-----45.1 in (114.6cm).

Motor-----15 brushless outrunner motor.

Radio-----4 channel with 2 servos.

Electric conversion: Optional.

www.seagullmodels.com

INTRODUCTION.

Thank you for choosing the **ANGEL 2000 GLIDER ARTF** by **SEAGULL MODELS COMPANY LTD.**, The **ANGEL 2000 GLIDER** was designed with the intermediate/advanced sport flyer in mind. It is a semi scale airplane which is easy to fly and quick to assemble. The airframe is conventionally built using balsa, plywood to make it stronger than the average ARTF, yet the design allows the aeroplane to be kept light. You will find that most of the work has been done for you already. The motor mount has been fitted and the hinges are pre-installed. Flying the **ANGEL 2000 GLIDER** is simply a joy.

This instruction manual is designed to help you build a great flying aeroplane. Please read this manual thoroughly before starting assembly of your **ANGEL 2000 GLIDER**. Use the parts listing below to identify all parts.

WARNING.

Please be aware that this aeroplane is not a toy and if assemble or used incorrectly it is capable of causing injury to people or property. WHEN YOU FLY THIS AEROPLANE YOU ASSUME ALL RISK & REponsibility.

If you are inexperienced with basic RC flight we strongly recommend you contact your RC supplier and join your local RC model Flying Club. RC Model Flying Clubs offer a variety of training procedures designed to help the new pilot on his way to successful RC flight. They will also be able to advise on any insurance and safety regulations that may apply.

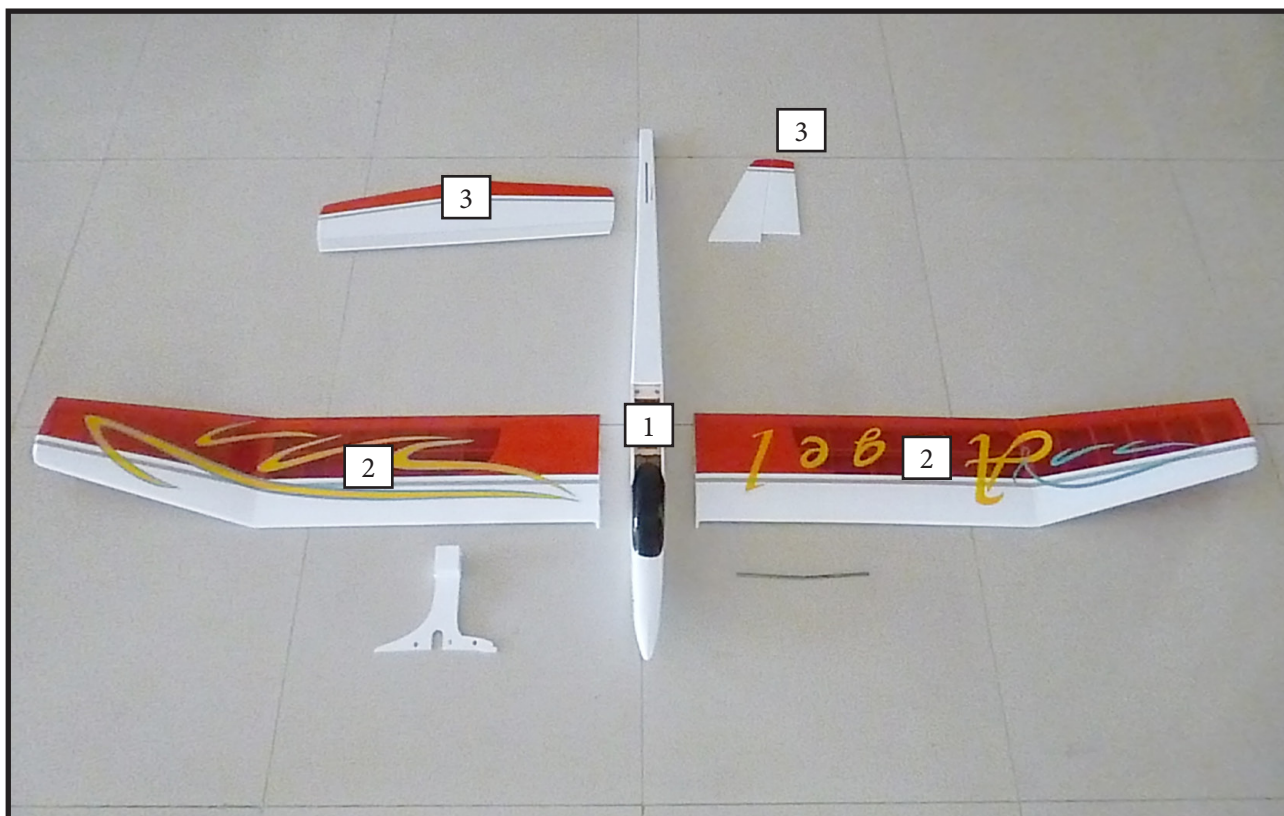
KIT CONTENTS

KIT CONTENTS.

SEA12901	Fuselage
SEA12902	Wing set
SEA12903	Tail set

ADDITIONAL ITEMS REQUIRED.

- 15 brushless outrunner motor.
- Radio 4 channel with 2 servos.

TOOLS & SUPPLIES NEEDED.

- Thick cyanoacrylate glue.
- 30 minute epoxy.
- 5 minute epoxy.
- Hand or electric drill.
- Assorted drill bits.
- Modelling knife.
- Straight edge ruler.
- 2mm ball driver.
- Phillips head screwdriver.
- 220 grit sandpaper.
- 90° square or builder's triangle.
- Wire cutters.
- Masking tape & T-pins.
- Thread-lock.
- Paper towels.

HINGING THE RUDDER.

Note : *The control surfaces, including the ailerons, elevators, and rudder, are prehinged with hinges installed, but the hinges are not glued in place. It is imperative that you properly adhere the hinges in place per the steps that follow using a high-quality thin C/A glue.*

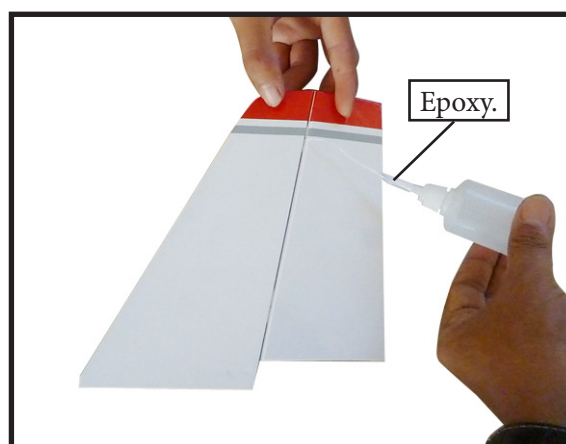
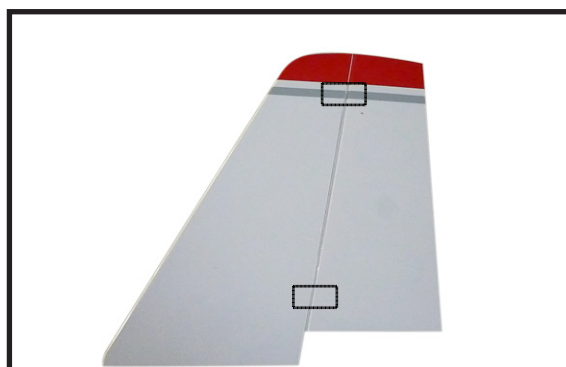
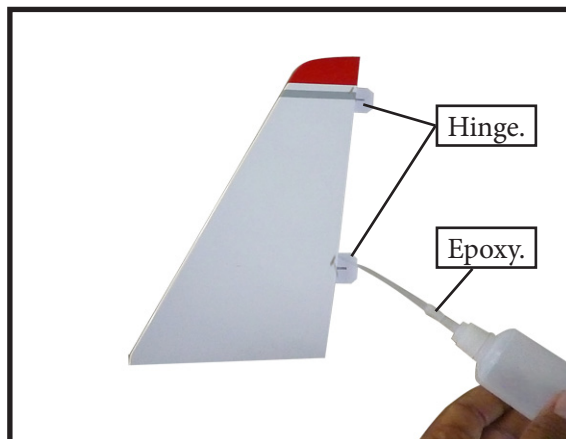

HINGING THE ELEVATORS.

Glue the elevator hinges in place using the same techniques used to hinge the rudder.

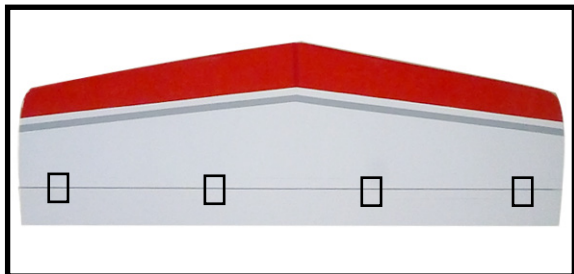

INSTALLING THE HORIZONTAL STABILIZER.

1) Using a ruler and a pen, locate the center-line of the horizontal stabilizer, at the trailing edge, and place a mark. Use a triangle and extend this mark, from back to front, across the top of the stabilizer. Also extend this mark down the back of the trailing edge of the stabilizer.

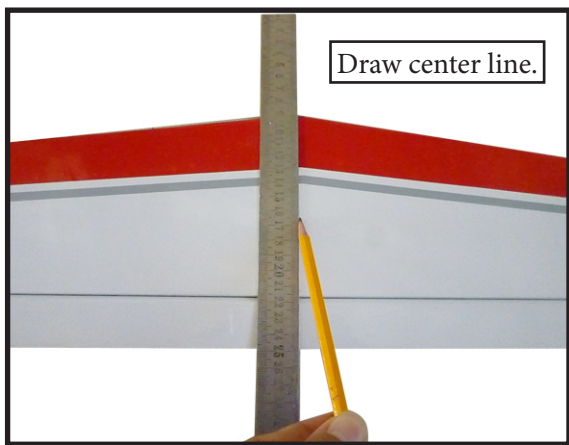

2) Using a modeling knife, carefully remove the covering at mounting slot of horizontal stabilizer (both side of fuselage).

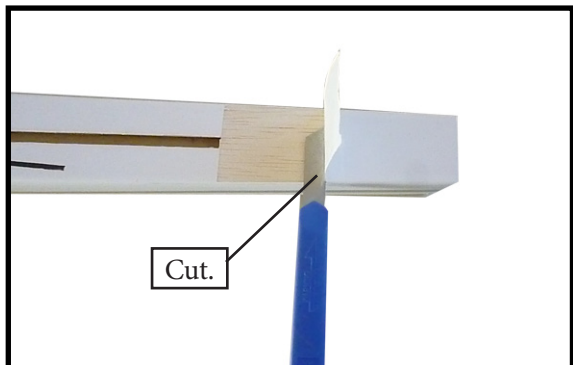

3) Slide the stabilizer into place in the precut slot in the rear of the fuselage. The stabilizer should be pushed firmly against the front of the slot.

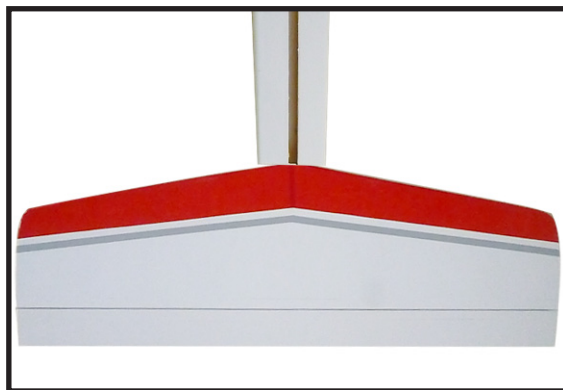

4) With the stabilizer held firmly in place, use a pen and draw lines onto the stabilizer where it and the fuselage sides meet. Do this on both the right and left sides and top and bottom of the stabilizer.

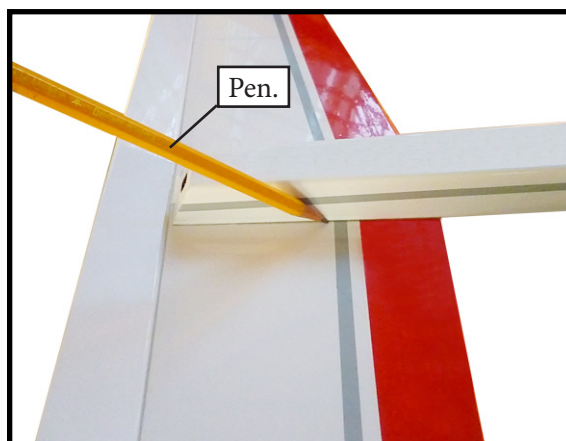

5) Remove the stabilizer. Using the lines you just drew as a guide, carefully remove the covering from between them using a modeling knife.

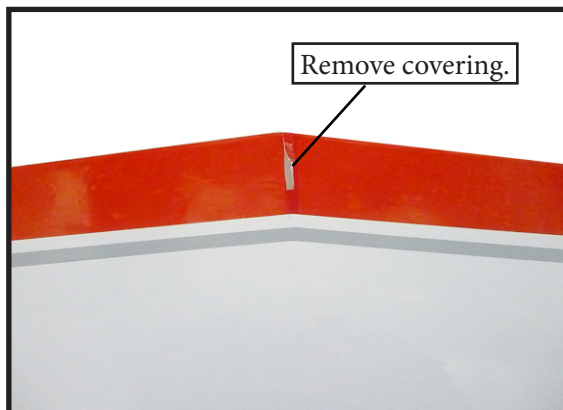

 When cutting through the covering to remove it, cut with only enough pressure to only cut through the covering itself. Cutting into the balsa structure may weaken it.

6) Using a modeling knife, carefully remove the covering that overlaps the stabilizer mounting platform sides in the fuselage. Remove the covering from both the top and the bottom of the platform sides.

7) When you are sure that everything is aligned correctly, mix up a generous amount of 30-minute epoxy. Apply a thin layer to the top and bottom of the stabilizer mounting area and to the stabilizer mounting platform sides in the fuselage. Slide the stabilizer in place and realign. Double check all of your measurements once more before the epoxy cures. Hold the stabilizer in place with T-pins or masking tape and remove any excess epoxy using a paper towel and rubbing alcohol.

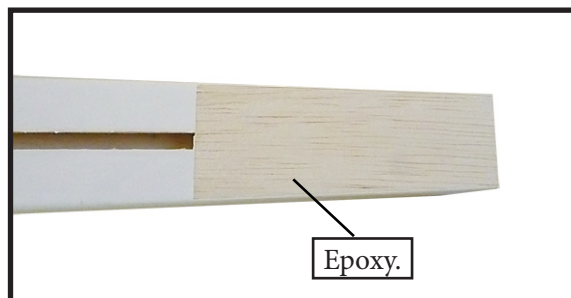
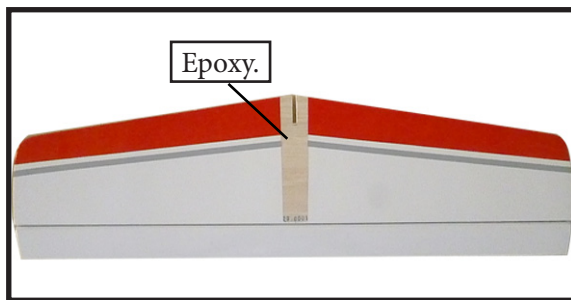
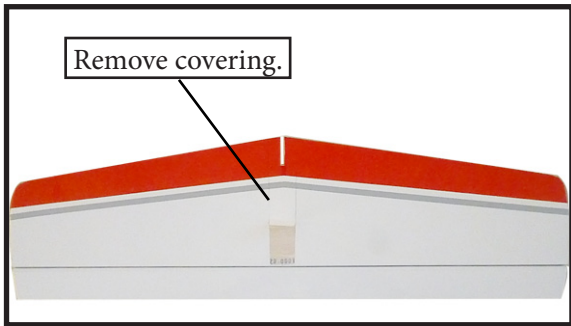

8) *Next assemble and install the elevator control horn.*

Start each screw partway into the holes in the control horn, as shown. Thread the screws in until the tip of each screw protrudes just slightly from the bottom of the horn base.

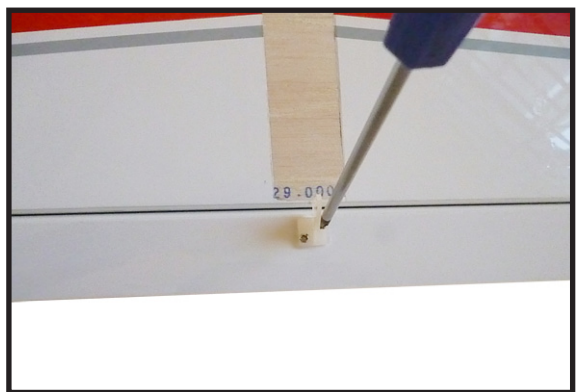
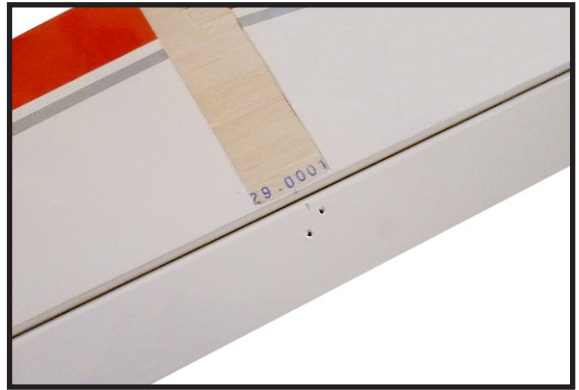
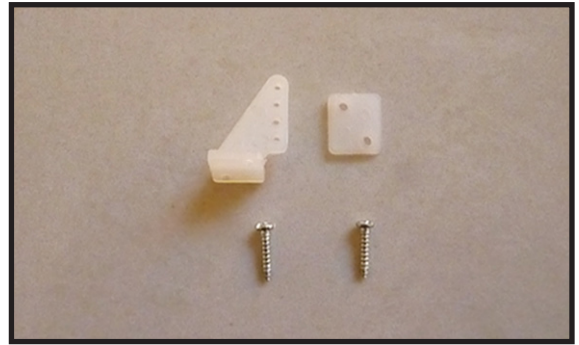

Then hold the control horn clamping plate in place while you finish threading the screws all the way in. When done, you can file or grind off the protruding sharp point of the screws if you desire.

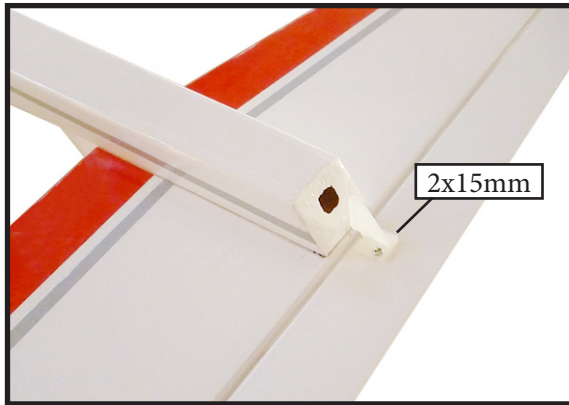

INSTALLING VERTICAL STABILIZER.

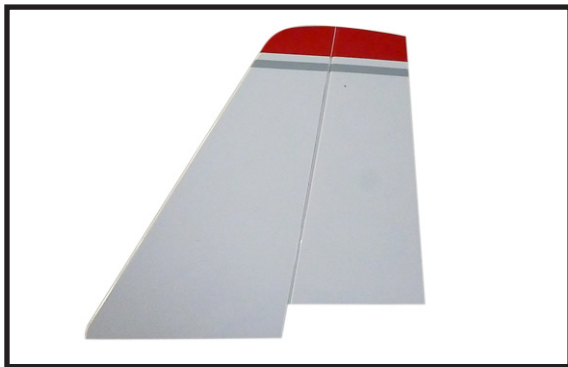

1) While holding the vertical stabilizer firmly in place, use a pen and draw a line on each side of the vertical stabilizer where it meets the top of the fuselage.

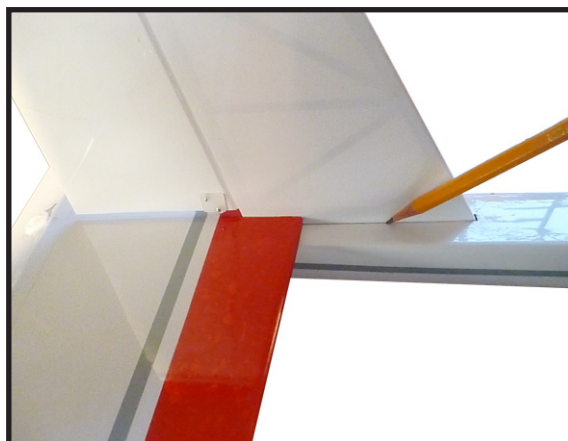

2) Using a modeling knife, remove the covering from over the precut hinge slot cut into the lower rear portion of the fuselage.

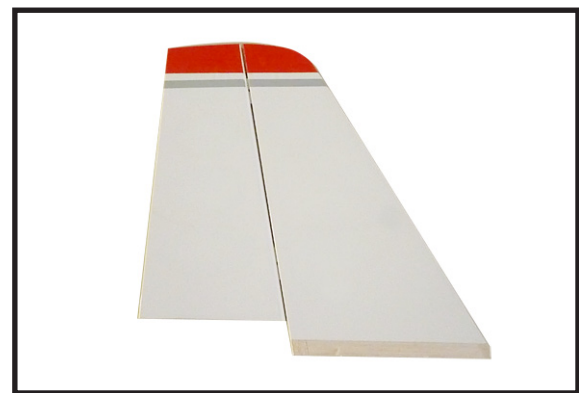
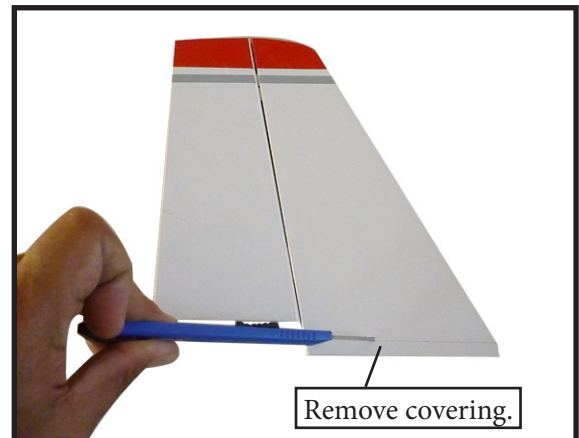

3) Next assemble and install the rudder control horn as the process for elevator control horn.



! *When cutting through the covering to remove it, cut with only enough pressure to only cut through the covering itself. Cutting into the balsa structure may weaken it.*

4) Slide the vertical stabilizer back in-place. Using a triangle, check to ensure that the vertical stabilizer is aligned 90° to the horizontal stabilizer.

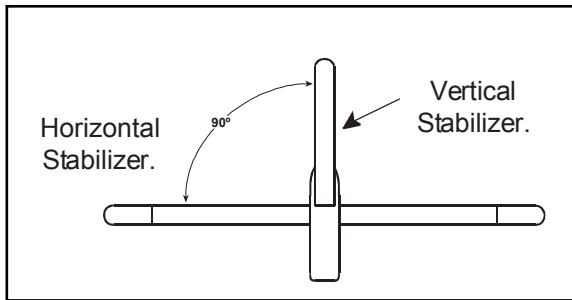

6) When you are sure that everything is aligned correctly, mix a generous amount of 30-minute epoxy. Apply a thin layer to the mounting slot and to bottom of the vertical stabilizer mounting area. Apply epoxy to the bottom and top edges of the filler block and to the lower hinge also. Set the stabilizer in place and realign. Double check all of your measurements once more before the epoxy cures. Hold the stabilizer in place with T-pins or masking tape and remove any excess epoxy using a paper towel and rubbing alcohol. Allow the epoxy to fully cure before proceeding.



INSTALLING THE FUSELAGE SERVOS.

 Because the size of servos differ, you may need to adjust the size of the precut opening in the mount. The notch in the sides of the mount allow the servo lead to pass through.

1) Install the rubber grommets and brass collets onto the fuselage servo. Test fit the servo into the aileron servo mount.

2) Secure the servos with the screws provided with your radio system.

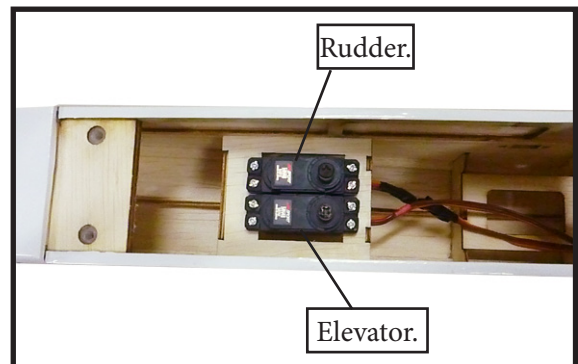

SERVO ARM INSTALLATION.

Install adjustable servo connector in the servo arm as same as picture below:

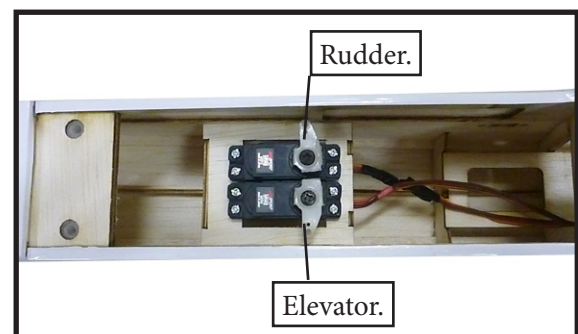

ELEVATOR - RUDDER PUSHROD HORN INSTALLATION.

1) Install the elevator control horn using the same method as with the aileron control horns.

2) Position the elevator control horn on the both side of elevator.

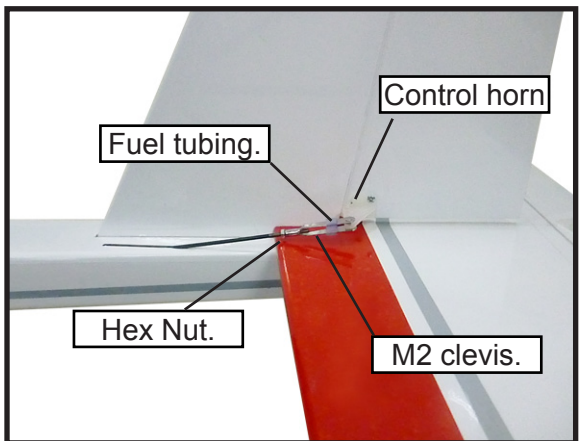
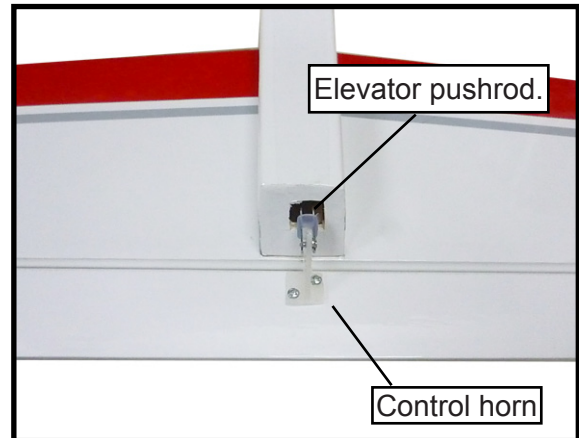
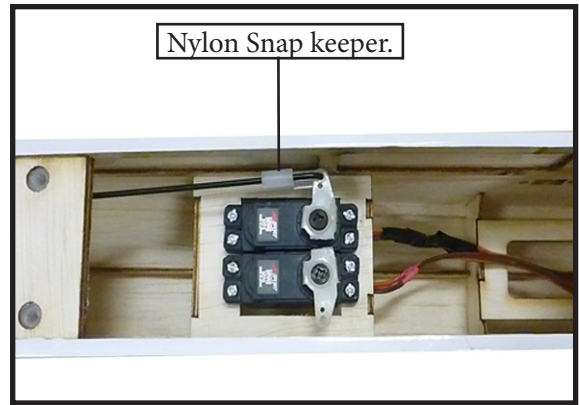
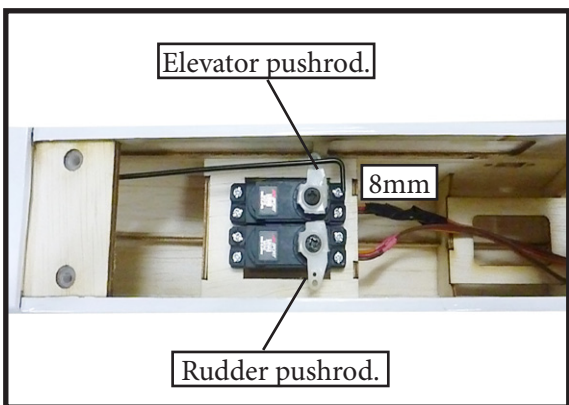
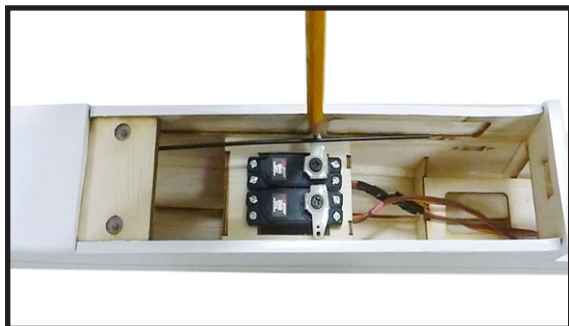
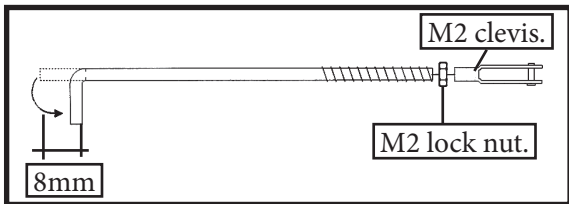

WING ASSEMBLY.

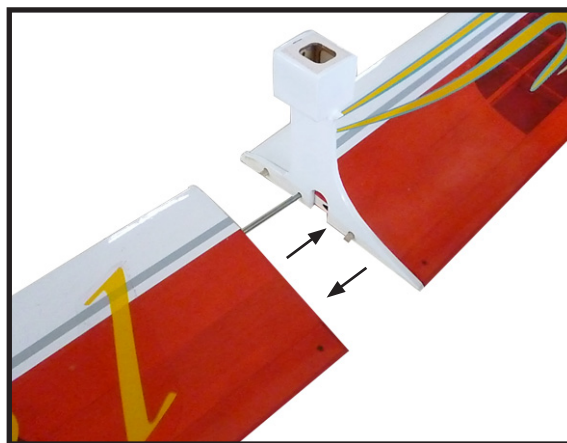
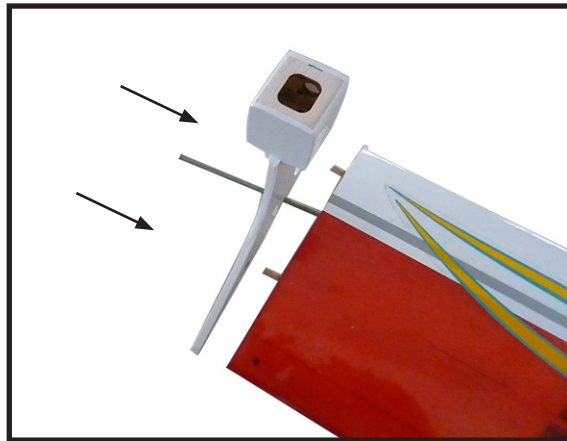
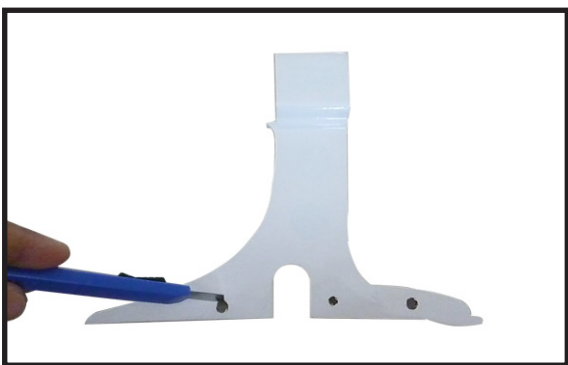
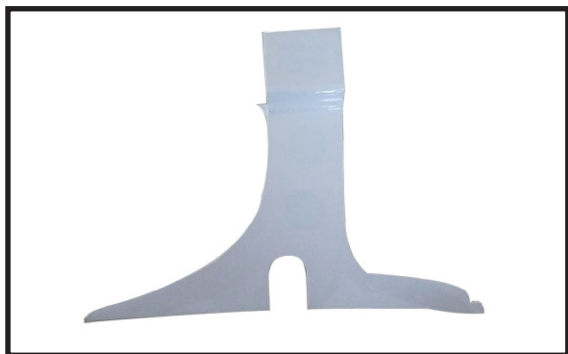
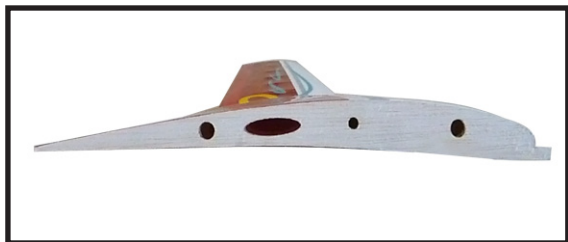
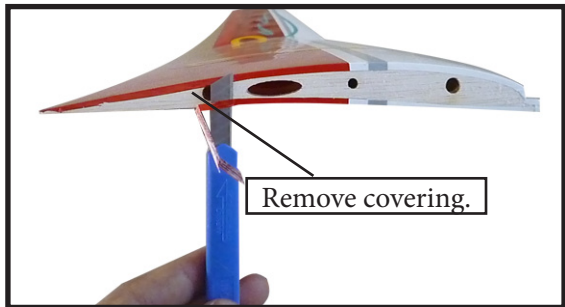

ELECTRIC POWER CONVERSION.

Locate the items necessary to install the electric power conversion included with your model.

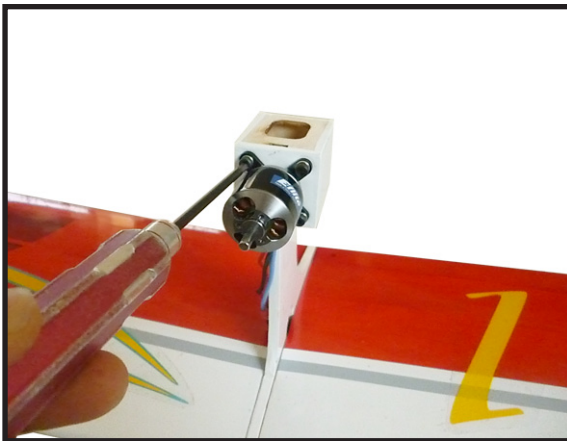
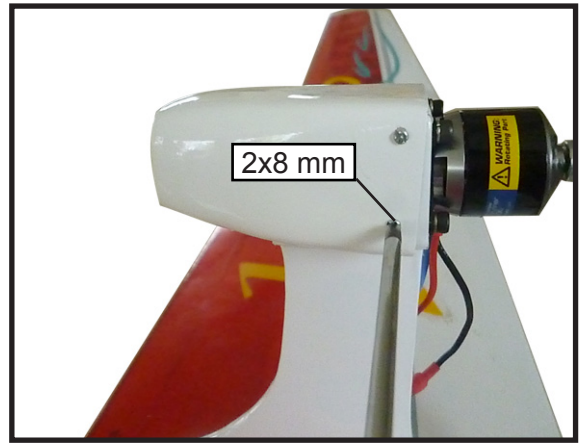
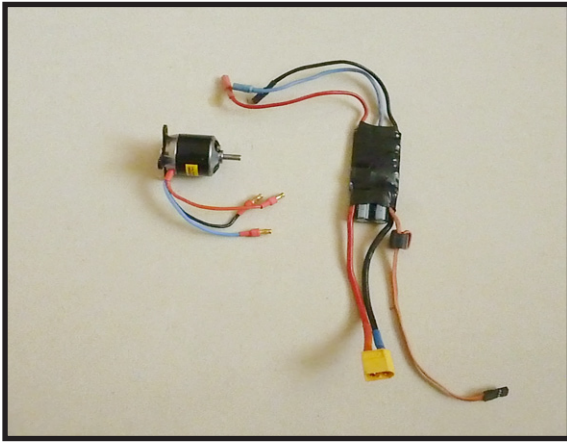

INSTALLING THE SPINNER.

Install the spinner backplate, propeller and spinner cone.

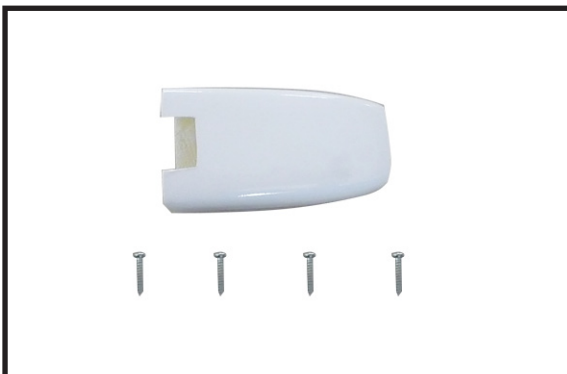
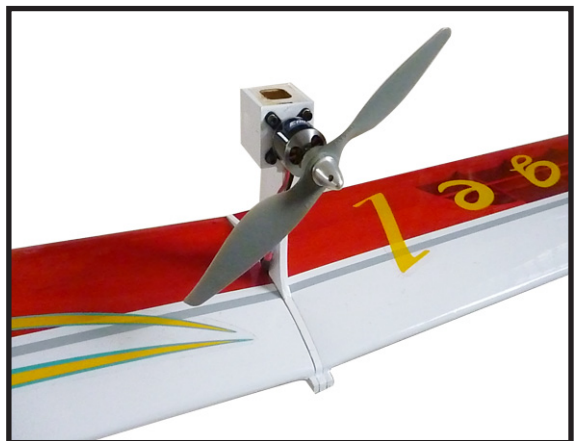
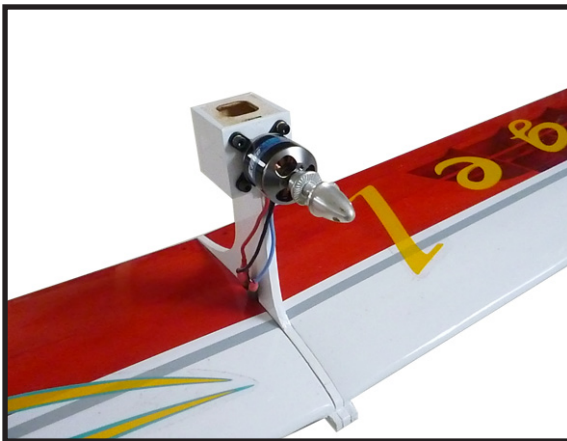

! The propeller should not touch any part of the spinner cone. If it does, use a sharp modeling knife and carefully trim away the spinner cone where the propeller comes in contact with it.

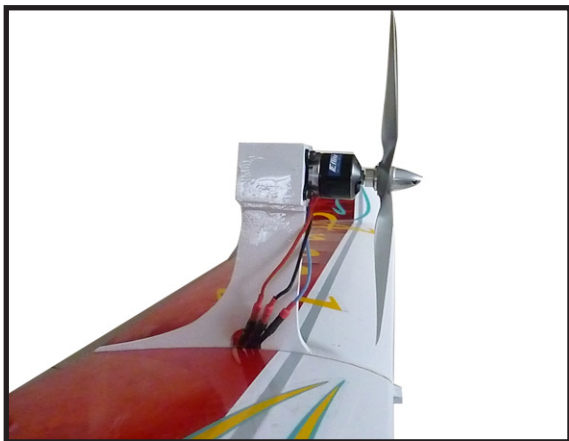

INSTALLING THE BATTERY - RECEIVER.

- 1) Plug the five servo leads and the switch lead into the receiver. Plug the battery pack lead into the switch also.
- 2) Wrap the receiver and battery pack in the protective foam rubber to protect them from vibration.
- 3) Route the antenna in the antenna tube inside the fuselage and secure it to the bottom of fuselage using a plastic tape.

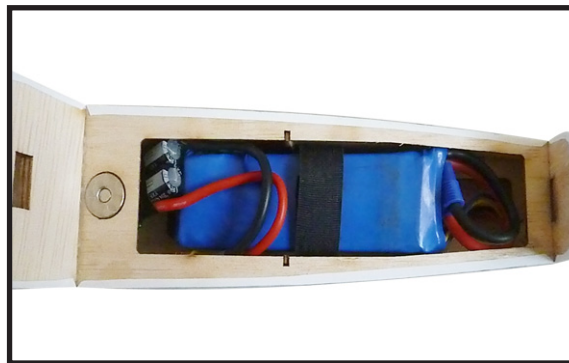
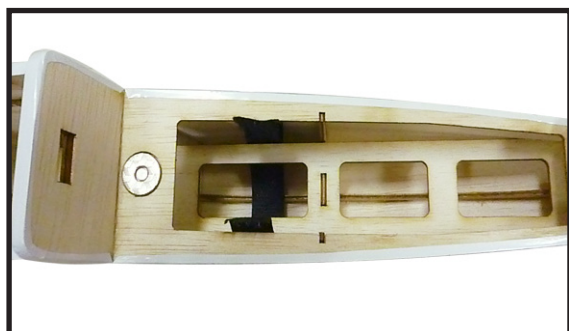
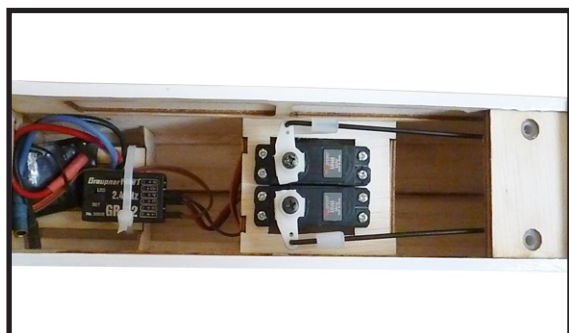

ATTACHMENT WING- FUSELAGE.

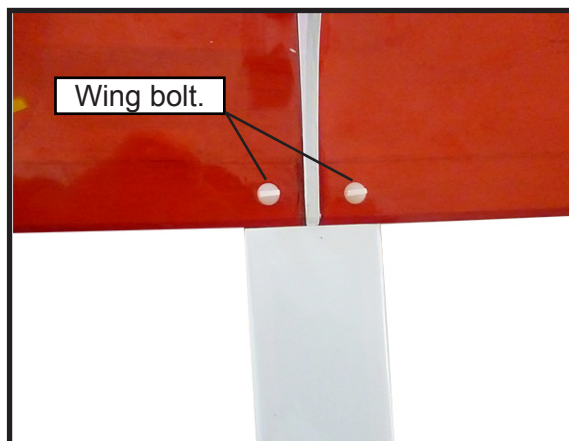
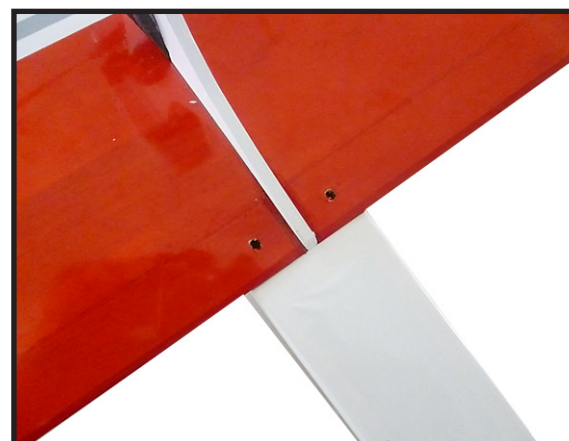

ATTACHMENT HATCH COVER ON THE FUSELAGE.

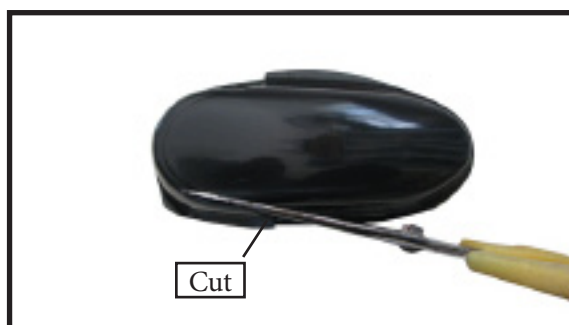



BALANCING.

1) It is critical that your airplane be balanced correctly. Improper balance will cause your plane to lose control and crash. THE CENTER OF GRAVITY IS LOCATED **86MM** BACK FROM THE LEADING EDGE OF THE WING AT THE WING ROOT.

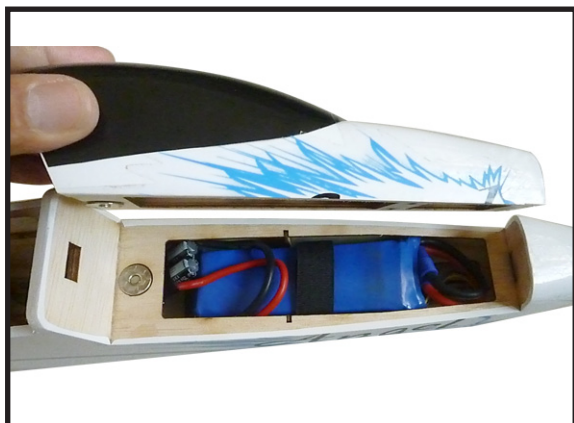

2) Mount the wing to the fuselage. Using a couple of pieces of masking tape, place them on the bottom side of the wing **86mm** back from the leading edge of the wing at the wing root.

3) It should hang level when suspended at the recommended balance point. Place your fingers on the masking tape and

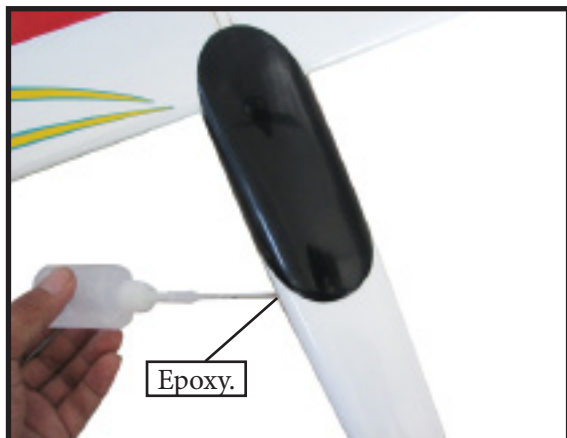

Accurately mark the balance point on the bottom of the wing on both sides of the fuselage. The balance point is located **86mm** back from the leading edge of the wing at the wing root. This is the balance point at which your model should balance for your first flights. Later, you may wish to experiment by shifting the balance up to 10mm forward or back to change the flying characteristics.

Moving the balance aft makes the model more agile with a lighter and snappier "feel". In any case, please start at the location we recommend.

With the wing attached to the fuselage, all parts of the model installed (ready to fly), and empty fuel tanks, hold the model at the marked balance point with the stabilizer level.

Lift the model. If the tail drops when you lift, the model is "tail heavy" and you must add weight* to the nose. If the nose drops, it is "nose heavy" and you must add weight* to the tail to balance.

*If possible, first attempt to balance the model by changing the position of the receiver battery and receiver. If you are unable to obtain good balance by doing so, then it will be necessary to add weight to the nose or tail to achieve the proper balance point.

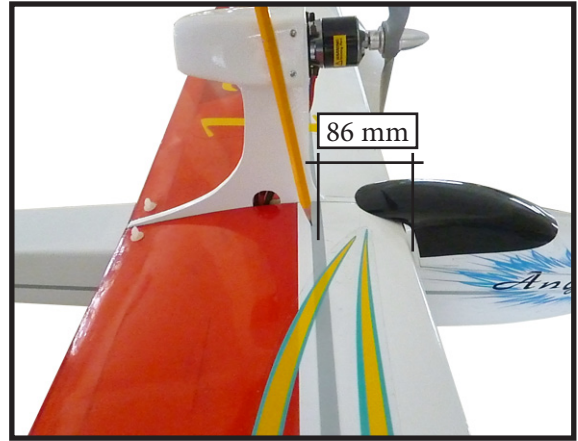

CONTROL THROWS.

Elevator:	
Up :	15 mm
Down :	15 mm
Rudder:	
Right :	20 mm
Left :	20 mm

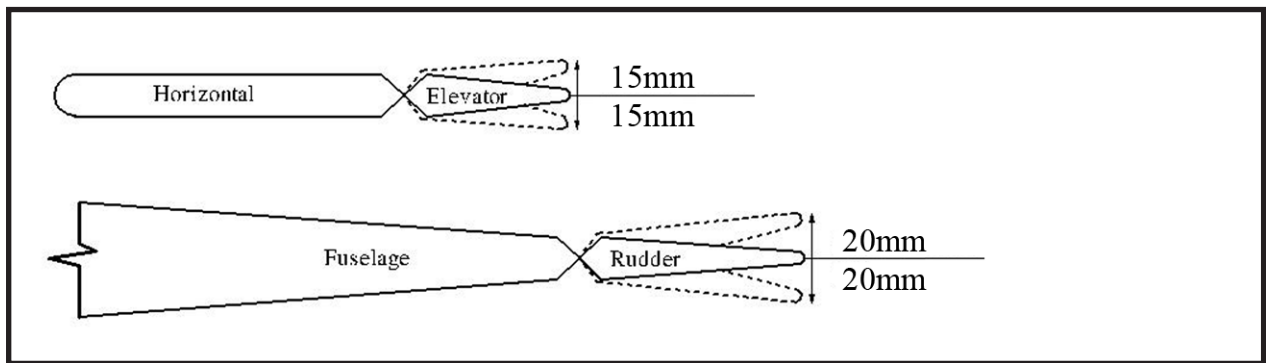

FLIGHT PREPARATION.

Check the operation and direction of the elevator, rudder, ailerons and throttle.

A) Plug in your radio system per the manufacturer's instructions and turn everything on.

B) Check the elevator first. Pull back on the elevator stick. The elevator halves should move up. If they do not, flip the servo reversing switch on your transmitter to change the direc-

C) Check the rudder. Looking from behind the airplane, move the rudder stick to the right. The rudder should move to the right. If it does not, flip the servo reversing switch on your transmitter to change the direction.

PREFLIGHT CHECK.

1) Completely charge your transmitter and receiver batteries before your first day of flying.

2) Check every bolt and every glue joint in the **ANGEL 2000 GLIDER** to ensure that everything is tight and well bonded.

3) Double check the balance of the airplane. Do this with the fuel tank empty.

4) Check the control surfaces. All should move in the correct direction and not bind in any way.

5) If your radio transmitter is equipped with dual rate switches double check that they are on the low rate setting for your first few flights.

6) Check to ensure the control surfaces are moving the proper amount for both low and high rate settings.

7) Check the receiver antenna. It should be fully extended and not coiled up inside the fuselage.

8) Properly balance the propeller. An out of balance propeller will cause excessive vibration which could lead to engine and/or airframe failure.

*We wish you many safe and enjoyable flights
with your ANGEL 2000 GLIDER.*