

# 1400mm Sky Cruiser Operating Manual

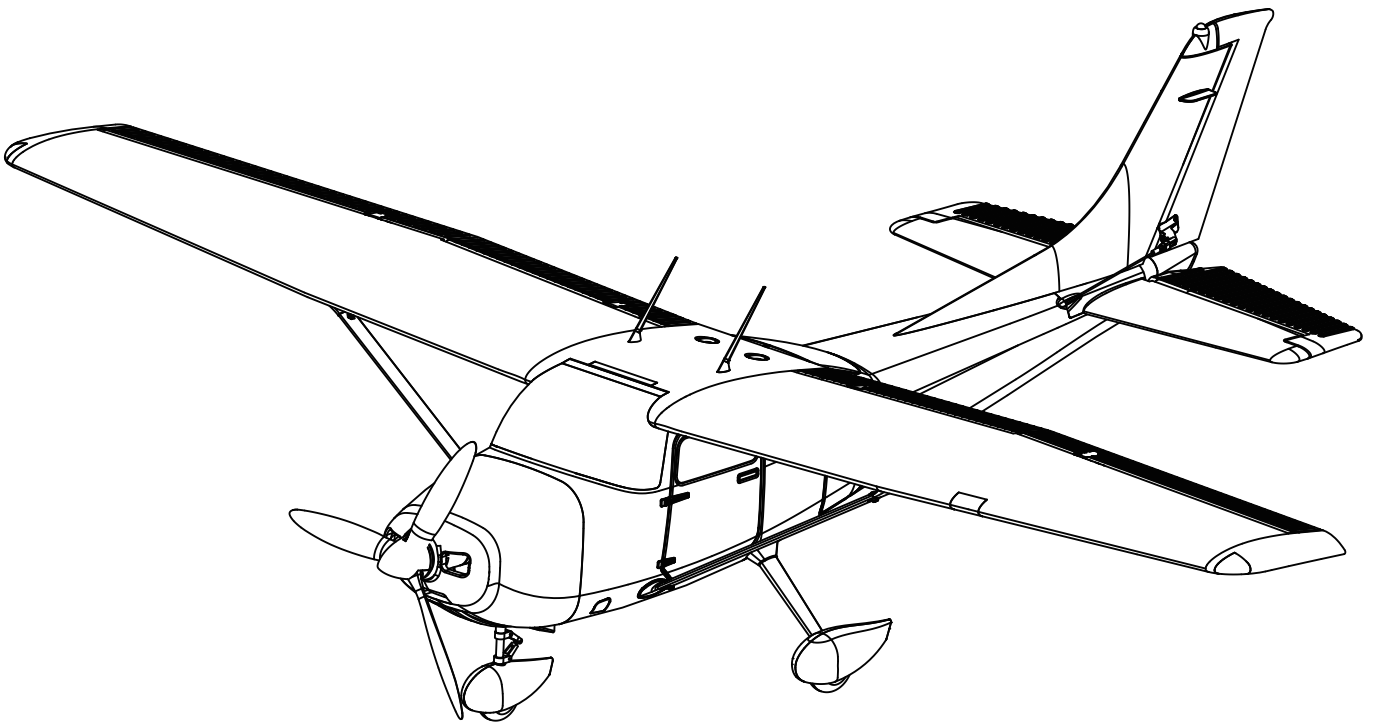

**Warning:** This manual contains important information that will help you maintain and operate your model aircraft in a reliable and safe manner. Please read the instructions and warnings carefully prior to assembly, setup or use.

As this model aircraft is a sophisticated hobby product, it must be flown with safety and common sense in mind, failure in doing so may result in injury or property damage. This product is not intended for use by children without direct adult supervision.

## Safety precautions and warnings

As the user, you are solely responsible for the safe operation and maintenance of this product. Follow the directions and warnings listed in this manual, as well as that of supporting equipment (chargers, batteries etc.) and always use common sense.

**This is not a toy. Not for children under 14 years of age.**

- ★Always operate your model in an open area away from buildings, cars, traffic or people. Never operate near people—especially children who can wander unpredictably. Never operate in populated areas for any reason, where injury or damage can occur.
- ★Always keep a safe distance in all directions around your model to avoid collisions or injury. This model is controlled by a radio signal subject to interference from many sources outside your control. Interference can cause momentary loss of control.
- ★Never catch the aircraft while it is in flight, the structure of the fuselage was not designed and protected for this purpose.
- ★Never operate your model in bad weather, including in excessively windy or precipitating conditions.
- ★Never operate your model with low transmitter batteries.
- ★Keep your throttle quadrant in its lowest position prior and after every flight. Use the throttle cut function if able.
- ★Always use fully charged batteries and move batteries before disassembly.
- ★Avoid water exposure to all equipment not specifically designed and protected for this purpose.
- ★Avoid cleaning this product with chemicals.
- ★Never lick or place any part of your model in your mouth as it could cause serious injury or even death.
- ★Keep all chemicals, small parts and anything electrical out of the reach of children.

## Table of contents

Specifications .....	2
Introduction .....	3
Kit contents .....	3
Model assembly .....	4
Battery installation .....	8
Receiver diagram .....	8
Center of gravity(CG).....	8
Preflight check .....	9
Clevis installation.....	9
Control horn and servo arm settings.....	10
Before flying the model .....	11
Flight tips.....	12
Trouble shooting .....	13
Spare parts list content .....	13

## Specifications

Wingspan	1,410mm/55.5in
Overall length	1,100mm/43.3in
Flying weight	~ 1,520g
Motor size	3536-KV850
Wing load	56.3g/d m <sup>2</sup>
Wing area	27d m <sup>2</sup>
Prop size	11*6 , 2-blade
ESC	40A
Servo	9g Servo x 6
Recommended battery	Li-Po 11.1V 2200mAh 25C

## Introduction

The Arrows Hobby 1400mm Sky Cruiser is a fantastic option for a training aircraft, offering stability, ease of flying, and simple controls.

The factory configuration includes a high-quality 40A ESC (Electronic Speed Controller), a 3536-KV850 motor and 6pcs 9g servos for precise control of flaps, ailerons, elevators, and rudder.

Featuring a "front three-point" landing gear, the aircraft is easy to control during landing, exhibits good ground stability, and is less prone to deviation and tipping during taxiing.

CNC machined metal front landing gear—with built-in CNC metal shock absorption and external use of realistic plastic components.

Five bright LED navigation lights are distributed on the left (red light x1, solid-on) and right (green light x1, solid-on) wing-tips, left wing (white lights X2, solid-on), and tail (red light X1, flashing), enhancing the enjoyment of flying and improving visibility.

An oversized cockpit canopy in a transparent brown vacuum-molded cabin, complete with a pilot and lifelike instrument panel adds fun and scale realism to the flying experience.

Functional flaps (movable).

Plastic strut braces effectively increase wing strength, facilitating high-speed flight.

Realistic decorative antennas.

Efficient 11-inch three-blade propeller.

Constructed from lightweight and high-rigidity EPO foam.

Detailed aesthetics, excellent performance, stable flight, and sturdy landing gear make the Arrows Hobby 1400mm Sky Cruiser suitable for both beginners and advanced flight training.

## Kit contents

Before assembly, please inspect the contents of the kit. The photo below details the contents of the kit with labels. If any parts are missing or defective, please identify the name or part number (refer to the spare parts list near the end of the manual) then contact your local shop.

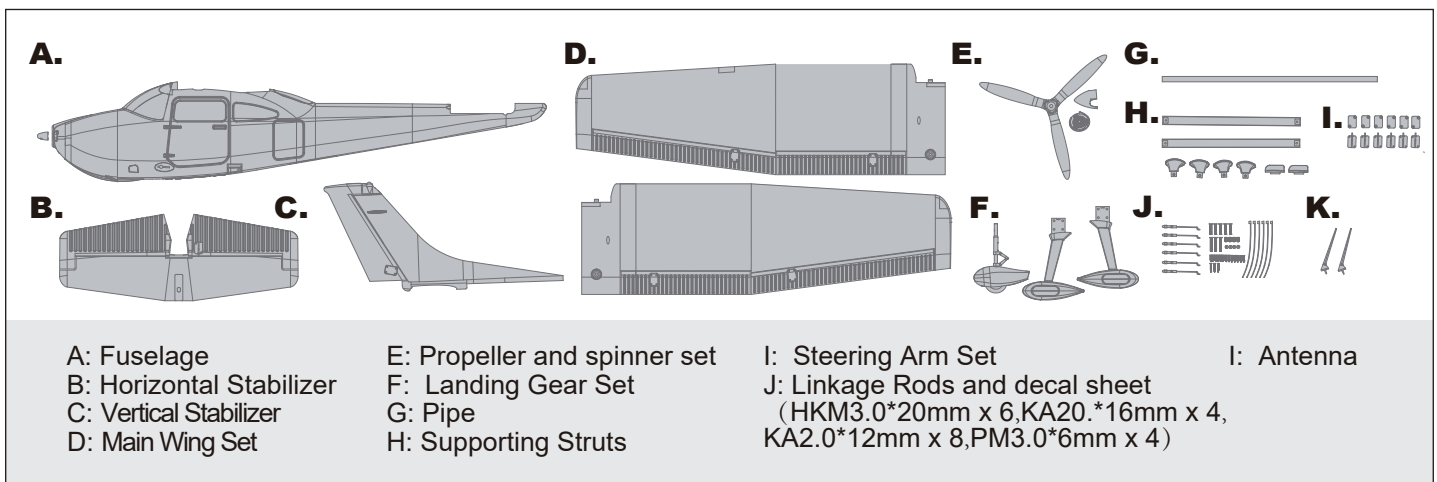

## Landing gear installation

1. Align the front landing gear with the installation hole at the bottom of the fuselage as shown and insert it.
2. Secure the front landing gear in place using the provided screw (PM2.0\*8mm x 1). Note that the provided screw should be installed from the direction of the air intake of the cowling, as shown, to maintain the integrity of the decal.

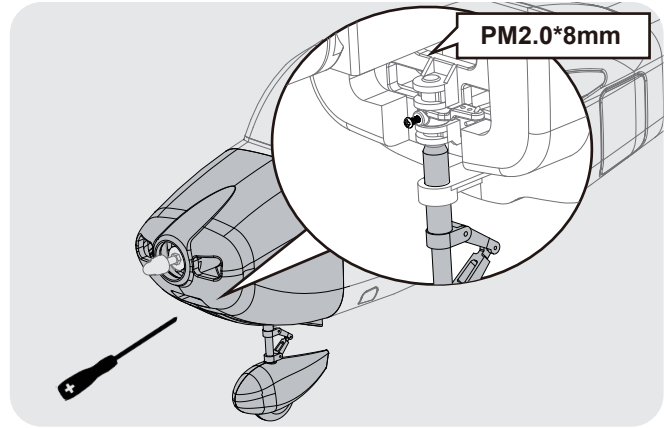
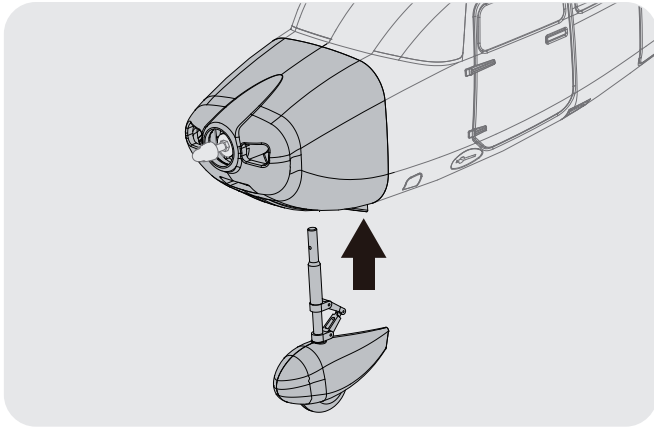

3. Keep the bottom of the fuselage facing upwards, install the main landing gear into the corresponding slots at the bottom of the fuselage, and secure it in place using the provided screws (HKM3.0\*20mm x 4).

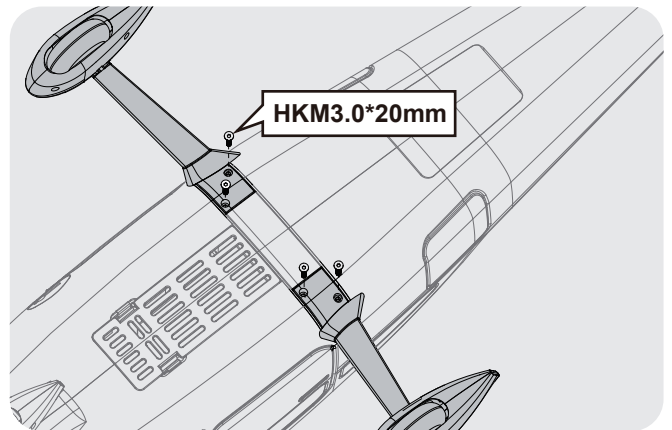

## Main wing Installation

Take out the control horns and bottom pads for the flaps and ailerons from the provided accessory package. Use the provided screws to secure the control horns and bottom pads into the slots on the flap and aileron surfaces. Note that the screws for securing the aileron surfaces are: KA2.0\*12mm x 2pcs. Different screw sizes are used for front and rear positions of flap surfaces: front (towards the nose): KA2.0\*16mm x 1pc, rear (towards the tail): KA2.0\*12mm x 1pc.

2. Install the linkage rods on the servo arm and control horn holes.

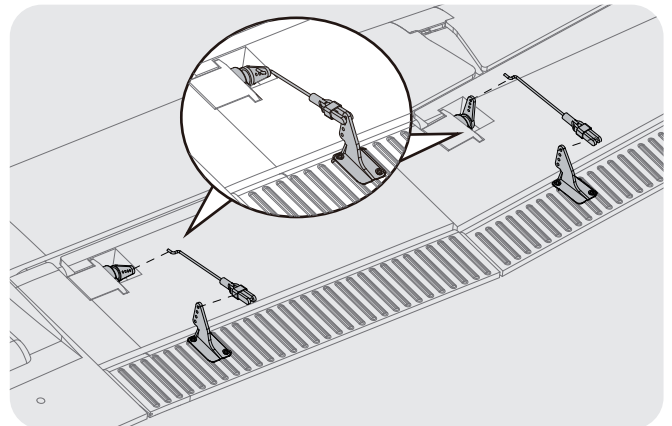
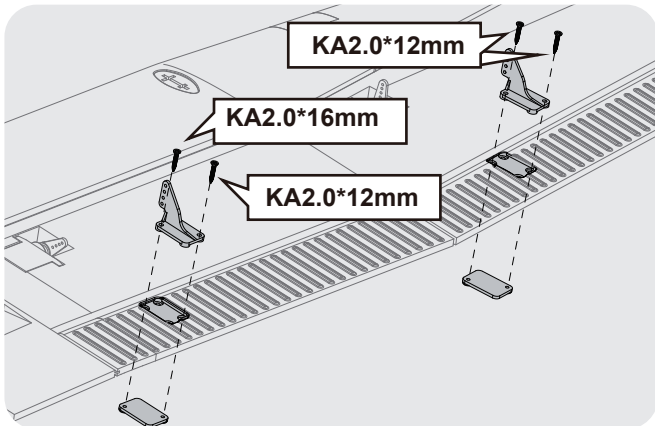

3. Take out the wing strut base required for the fuselage from the accessory package (the base has an anti-reverse design to prevent misplacement). Apply foam adhesive to both the contact surfaces of the fuselage slot and wing strut base as shown, then align and stick firmly.

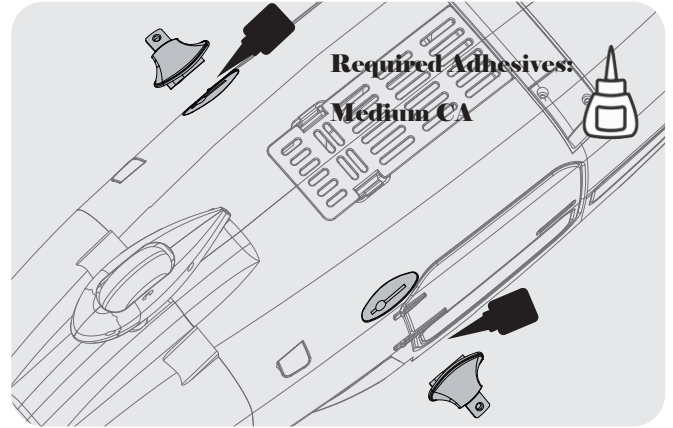

4. Take out the wing strut base required for the wing from the accessory package (the base has an anti-reverse design to prevent misplacement). Apply foam adhesive to both the contact surfaces of the wing slot and wing strut base as shown, then align and stick firmly.

5. Take out the realistic antenna from the accessory package. Apply foam adhesive to the contact surfaces of the wing slots and the bottom of the antenna as shown, then align and firmly bond them together.

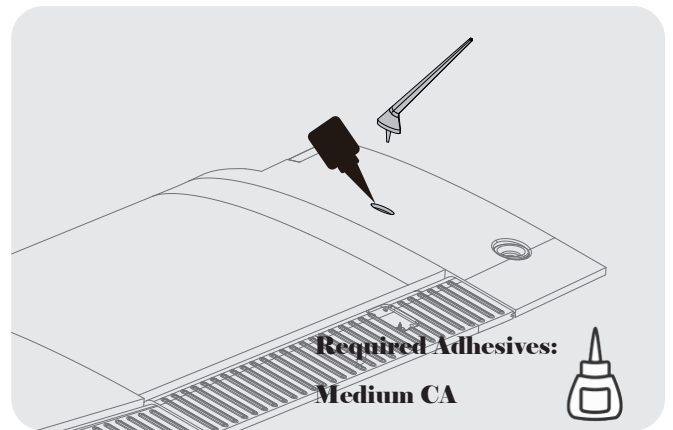
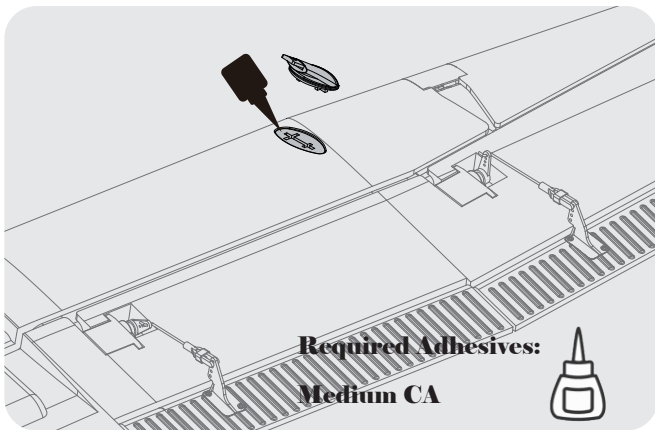

6. Install the left and right wings using the connecting tube.

Use the provided two 2Y wires to connect the left and right aileron servo wires and the left and right flap servo wires (please pay attention to the corresponding channel labels for connection). Use the provided one 3Y cable to connect the LED extension wires, then use zip ties to bundle the wires and route the wire bundle from the hole above the fuselage to the bottom of the fuselage for connecting to the receiver. Then use the included screws (HKM3.0\*20mm) to secure the main wing to the fuselage in place.

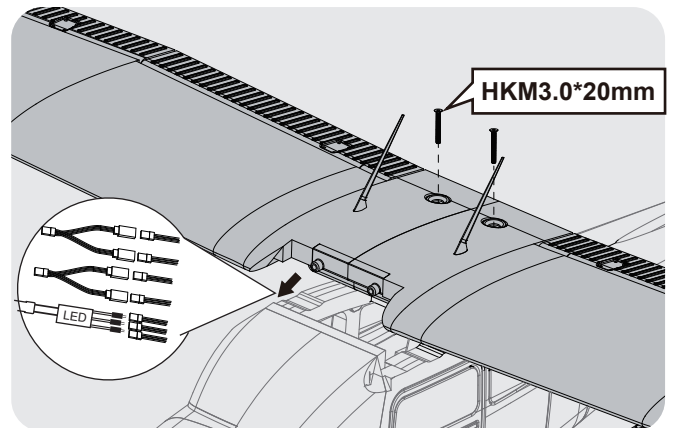
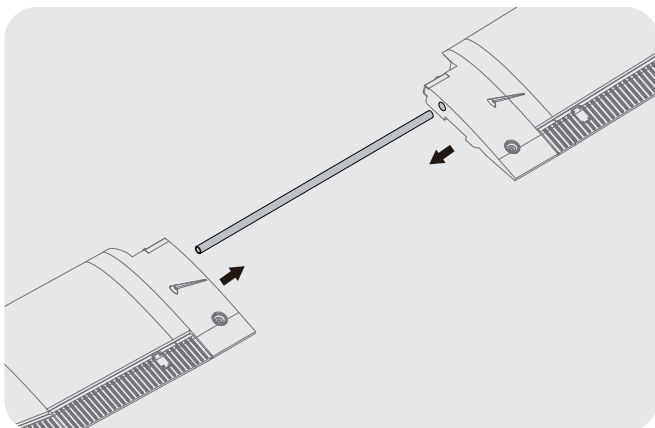

8. Install the strut rods to the fuselage base and main wing base respectively, and secure them with the provided screws (PM3.0\*6mm x 4) and nuts.

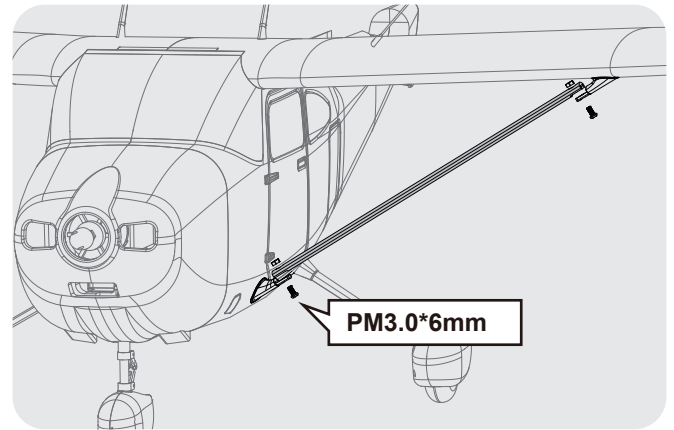

### Horizontal and vertical stabilizer installation

1. Take out the control horns and bottom pads for the elevator from the provided accessory package. Use the provided screws (KA2.0\*16mm x 2pcs) to secure the control horns and bottom pads into the slots on the elevator surface.

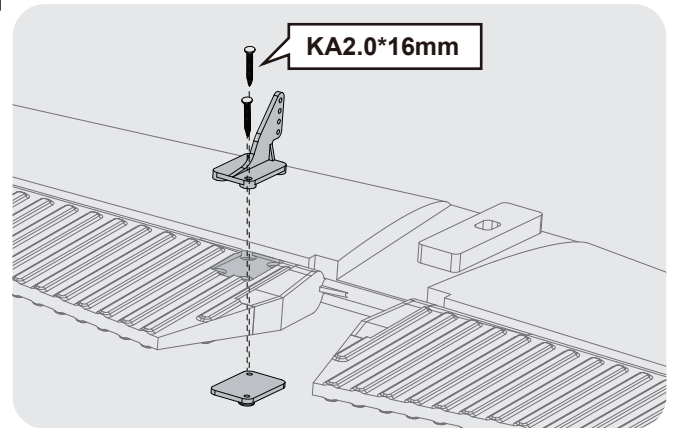

2. Take out the control horns and bottom pads for the rudder from the provided accessory package. Use the provided screws (KA2.0\*12mm x 2pcs) to secure the control horns and bottom pads into the slots on the rudder surface.

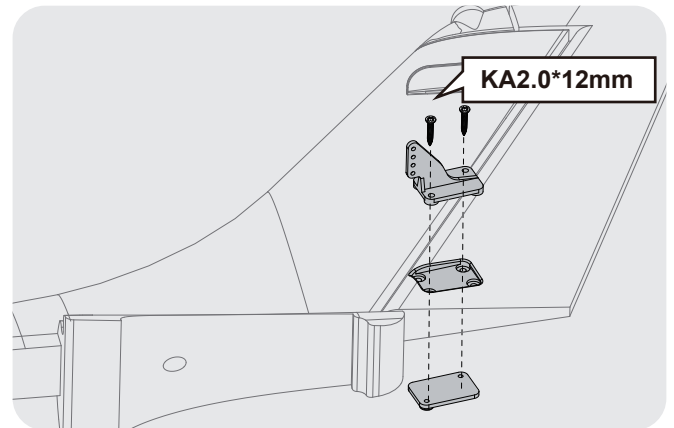

3. Guide the extension wire at the tail of the fuselage through the horizontal tail slot, apply foam glue to the horizontal tail and fuselage tail slot respectively, and install the horizontal tail onto the fuselage. Connect the extension wire to the LED wire from vertical tail, apply foam glue to the contact surfaces of the vertical tail and horizontal tail, and install the vertical tail onto the horizontal tail.

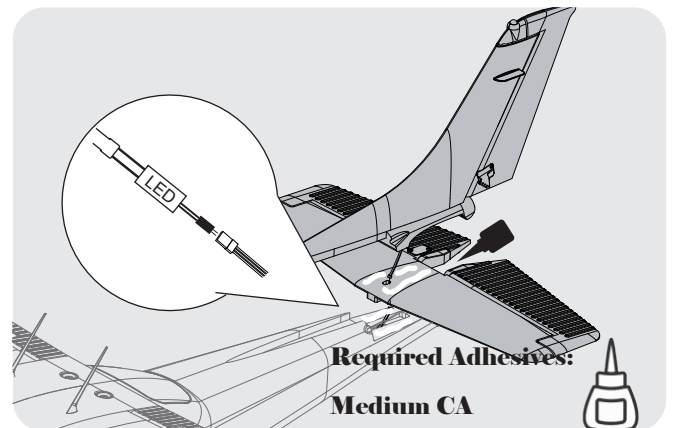

4. Install the linkage rod to the control horn of horizontal tail.
5. Install the linkage rod to the control horn of vertical tail.

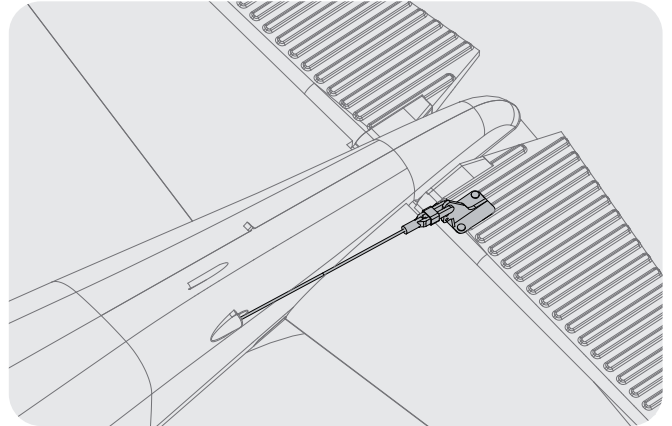
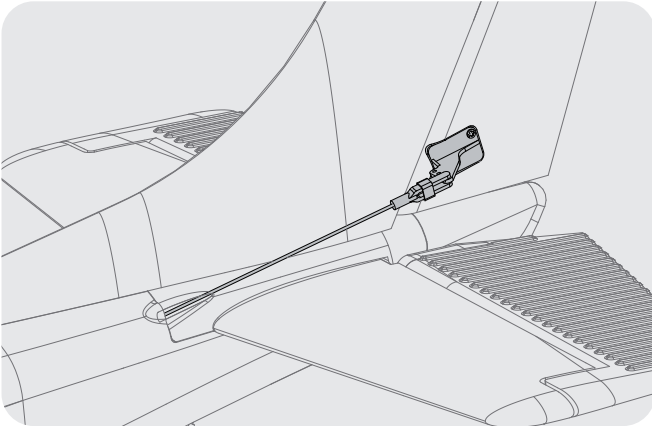

6. Apply foam glue to the contact surfaces of the realistic parts and the mounting slots on both sides of the vertical tail, and install the realistic parts onto the vertical tail as shown.

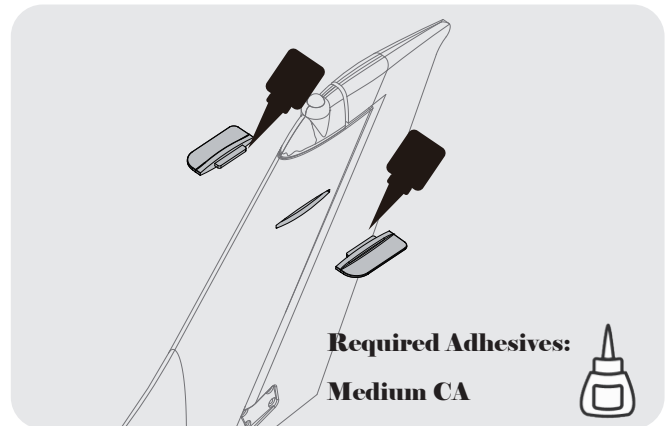

### Propeller installation

1. Assemble the spinner and propeller as shown.

*Note: the motor should rotate clockwise when viewing the plane from the rear.*

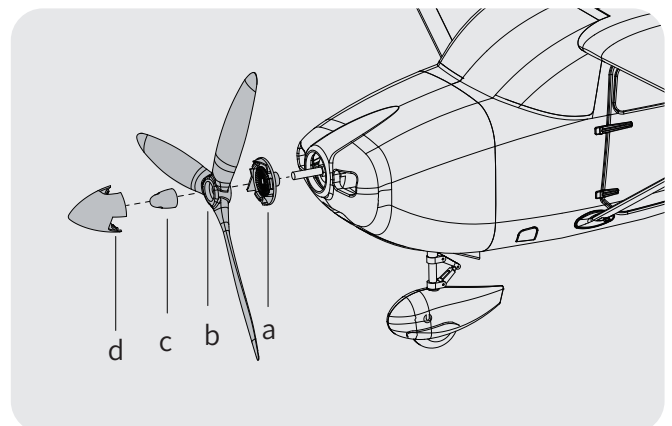

## «—— Battery installation

1. Remove the battery cover.
2. Remove the hook and loop tape from the fuselage. Apply the looped surface to the battery.
3. Install the battery into the fuselage- securing it with the preinstalled battery straps.

*Note: The weight of each battery may vary due to different manufacturing techniques. Move the battery fore or aft to achieve the optimal center of gravity.*

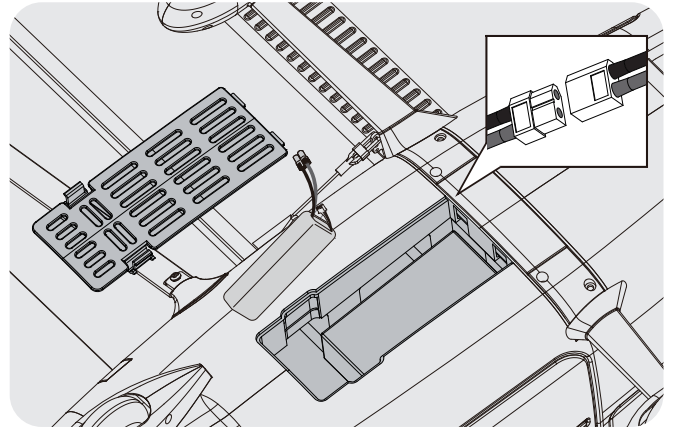

## Receiver diagram

The cables from the servo connector board should be connected to your receiver in the order shown. Note that the LEDs can be powered by any spare channel on the receiver. Tuck the wire leads into the recessed cavity towards the rear of the battery hatch.

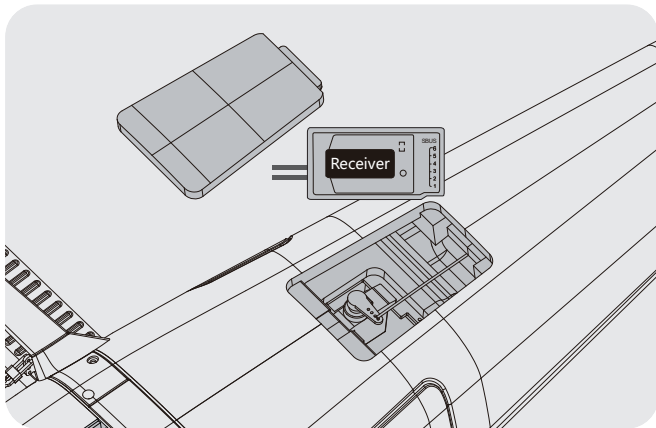

		Receiver
Aileron	1	Channel-1 — Aile
Elevator	2	Channel-2 — Elev
Throttle	3	Channel-3 — Thro
Rudder	4	Channel-4 — Rudd
Gear	5	Channel-5 — Gear
Flap	6	Channel-6 — Flap

## «—— Finding the center of gravity

Finding the correct center of gravity is critical in ensuring that the aircraft performs in a stable and responsive manner. Please adjust the weight distribution so the aircraft balances in the range stated on the diagram.

- Depending on the capacity and weight of your chosen flight batteries, move the battery forward or backward to adjust the center of gravity.
- If you cannot obtain the recommended CG by moving the battery to a suitable location, you can also install a counterweight to achieve correct CG. However, with the recommended battery size, a counterweight is not required. We recommend flying without unnecessary counterweight.

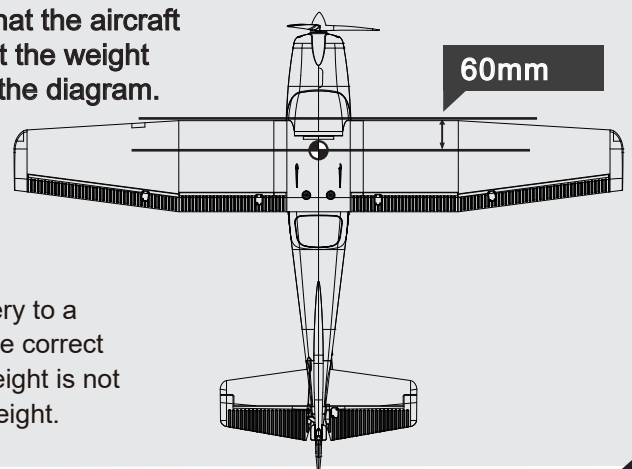

## «— Preflight check —»

### Important ESC and model information

1. The ESC included with the model has a safe start. If the motor battery is connected to the ESC and the throttle stick is not in the low throttle or off position, the motor will not start until the throttle stick is moved to the low throttle or off position. Once the throttle stick is moved to the low throttle or off position, the motor will emit a series of beeps. Several beeps with the same tune means the ESC has detected the cells of the battery. The count of the beeps equals the cells of the battery. The motor is now armed and will start when the throttle is moved.
2. The motor and ESC come pre-connected and the motor rotation should be correct. If for any reason the motor is rotating in the wrong direction, simply reverse two of the three motor wires to change the direction of rotation.
3. Battery Selection and Installation. We recommend the 11.1V 2200mAh 25C Li-Po battery. If using another battery, the battery must be at least a 11.1V 2200mAh 25C battery. Your battery should be approximately the same capacity, dimension and weight as the 11.1V 2200mAh 25C Li-Po battery to fit the fuselage without changing the center of gravity significantly.

### Control throws

*The suggested control throw setting for the Sky Cruiser are as follows (dual rate setting):*

Tip: The maiden flight should always be flown using low rates, fly the aircraft until you are familiar with its characteristics prior to trying high rates. Make sure the aircraft is flying at altitude and adequate velocity prior to using high rates, as the aircraft will be sensitive to control inputs with the larger control surface movements.

	High Rate	Low Rate
<b>Elevator</b>	10mm up / down	6mm up / down
<b>Aileron</b>	15mm up / down	10mm up / down
<b>Rudder</b>	9mm left / right	5mm left / right

## «— Clevis installation —»

1. Pull the tube from the clevis to the linkage.
2. Carefully spread the clevis, then insert the clevis pin into the desired hole in the control horn.
3. Move the tube to hold the clevis on the control horn.

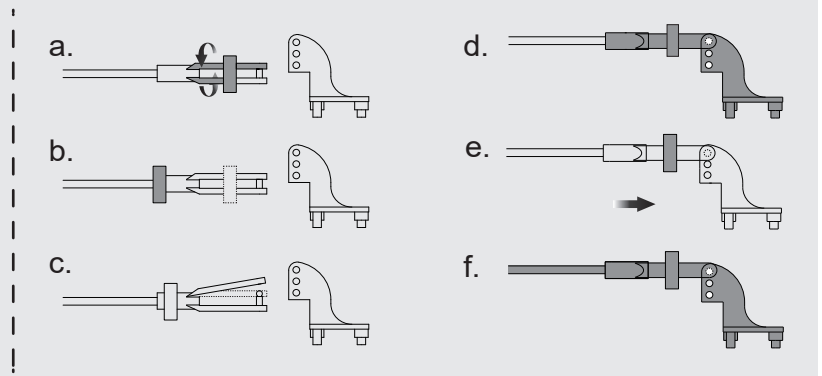

## Control horn and servo arm settings



1. The table shows the factory settings for the control horns and servo arms. Fly the aircraft at the factory settings before making changes.
2. After flying, you may choose to adjust the linkage positions for the desired control response.

	Horns	Arms
Elevator		
Rudder		
Ailerons		
Flap		

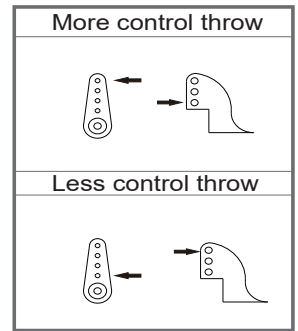

### transmitter and model setup

After assembly and prior to your first flight, make sure all control surfaces respond correctly to your transmitter by referring to the diagram below.

#### Aileron

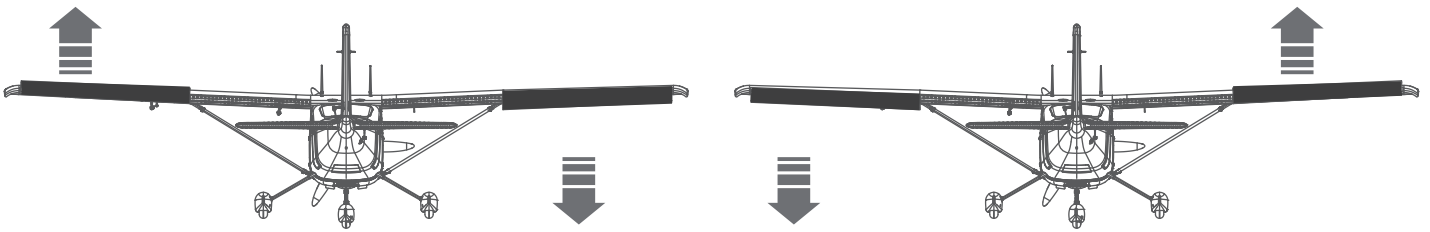

#### Elevator

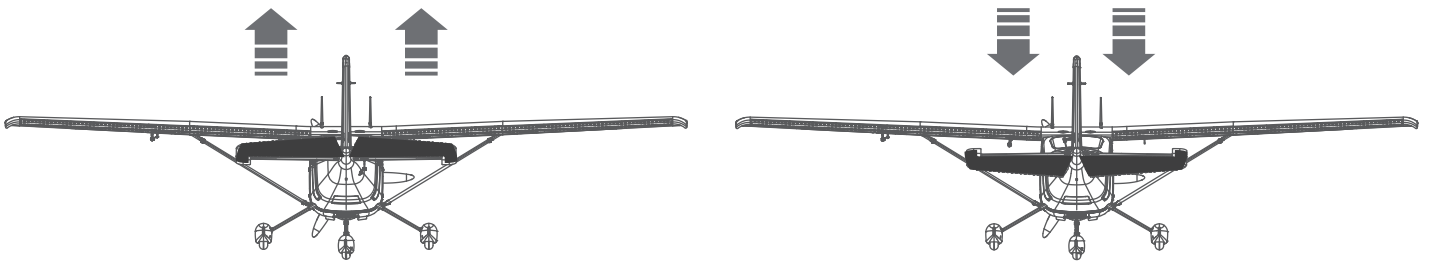

#### Rudder

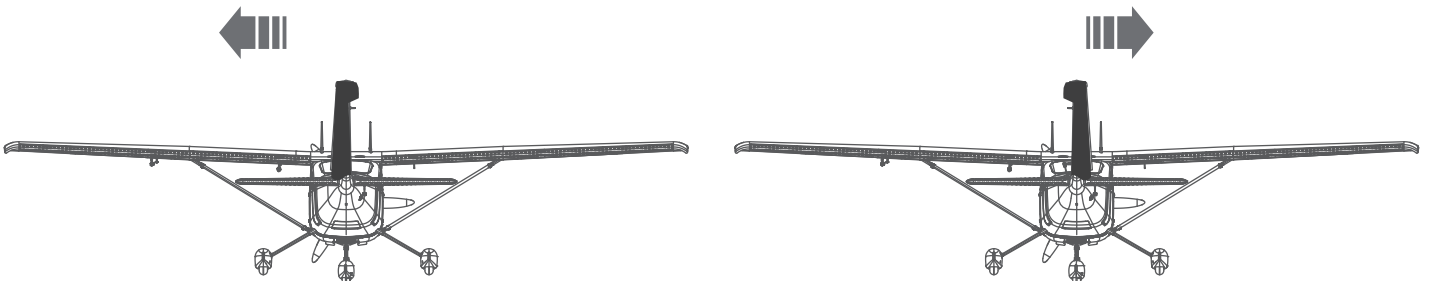

## « Before flying the model

---

### Find a suitable flying site

Find a flying site clear of buildings, trees, power lines and other obstructions. Until you know how much area will be required and have mastered flying your plane in confined spaces, choose a site which is at least the size of two to three football fields - a flying field specifically for R/C planes is best. Never fly near people - especially children, who can wander unpredictably.

---

### Performing a range check

A radio range check should be performed prior to the first flight of the day. This test may assist you in detecting electronic problems that may lead to a loss of control- problems such as low transmitter batteries, defective or damaged radio components or radio interference. This usually requires an assistant and should be done at the flying site.

Always turn your transmitter on first. Install a fully charged battery in the battery bay, then connect it to the ESC. In this process, make sure that the throttle cut functionality is on, and that the throttle stick is secured in its lowest position- otherwise, the propeller/fan will engage and possibly cause bodily harm.

**Note: Please refer to your transmitter manual that came with your radio control system to perform a ground range check. If the controls are not working correctly or if anything seems wrong, do not fly the model until you correct the problem. Make certain all the servo wires are securely connected to the receiver and the transmitter batteries have a good connection.**

---

### Monitor your flight time

Monitor and limit your flight time using a timer (such as a stopwatch or on the transmitter, if available). As modern Lithium Polymer batteries are not designed to discharge completely, when the battery runs low, the ESC will lower then completely cut the power to the motors to protect the battery. Often (but not always) power can be briefly restored after the motor cuts off by holding the throttle stick all the way down for a few seconds. To avoid an unexpected dead-stick landing on your first flight, set your timer to a conservative 4 minutes. When your alarm sounds you should land right away.



### Take off

Point the aircraft into the wind while slowly applying power until the aircraft starts to track straight, use the rudder when necessary. When the aircraft reaches takeoff speed, ease back on the elevator stick until the aircraft is climbing at a constant rate without decelerating. Climbing at too steep of an angle at the relatively low speeds of a takeoff-climb may result in an aerodynamic stall.

---

### Flying

Always choose a wide-open space for flying your plane. It is ideal for you to fly at a sanctioned flying field. If you are not flying at an approved site always avoid flying near houses, trees, wires and buildings. You should also be careful to avoid flying in areas where there are many people, such as busy parks, schoolyards, or soccer fields. Consult laws and ordinances before choosing a location to fly your aircraft. After takeoff, gain some altitude. Climb to a safe height before trying technical manoeuvres.

---

### Landing

Land the aircraft when you start to feel sluggish motor response. If using a transmitter with a timer, set the timer so you have enough flight time to make several landing approaches. The model's three point landing gear allows the model to land on hard surfaces. Align model directly into the wind and fly down to the ground. Fly the airplane down to the ground using 1/4-1/3 throttle to keep enough energy for proper flare. Before the model touches down, always fully decrease the throttle to avoid damaging the propeller or other components. The key to a great landing is to manage the power and elevator all the way to the ground and set down lightly on the main landing gear. With some practice, you will be able to set the aircraft gently on its main gear and hold it that way until the speed reduces enough where the nose wheel (tricycle landing gear aircraft) or tail wheel (tail draggers) settles onto the ground.

---

### Maintenance

Repairs to the foam should be made with foam safe adhesives such as hot glue, foam safe CA, and 5min epoxy. When parts are not repairable, see the spare parts list for ordering by item number. Always check to make sure all screws on the aircraft are tightened. Pay special attention to make sure the spinner is firmly in place before every flight.

## « Troubleshooting

<b>Problem</b>	<b>Possible Cause</b>	<b>Solution</b>
Aircraft will not respond to the throttle but responds to other controls.	<ul style="list-style-type: none"> <li>• ESC is not armed.</li> <li>• Throttle channel is reversed.</li> </ul>	<ul style="list-style-type: none"> <li>• Lower throttle stick and throttle trim to lowest settings.</li> <li>• Reverse throttle channel on transmitter.</li> </ul>
Excessive vibration or propeller noise.	<ul style="list-style-type: none"> <li>• Damaged spinner, propeller, motor or motor mount.</li> <li>• Loose propeller and spinner parts.</li> <li>• Propeller installed backwards.</li> </ul>	<ul style="list-style-type: none"> <li>• Replace damaged parts.</li> <li>• Tighten parts for propeller adapter, propeller and spinner.</li> <li>• Remove and install propeller correctly.</li> </ul>
Reduced flight time or aircraft underpowered.	<ul style="list-style-type: none"> <li>• Flight battery charge is low.</li> <li>• Propeller installed backward.</li> <li>• Flight battery damaged.</li> </ul>	<ul style="list-style-type: none"> <li>• Completely recharge flight battery.</li> <li>• Replace flight battery and follow flight battery instructions.</li> </ul>
Control surfaces unresponsive or sluggish.	<ul style="list-style-type: none"> <li>• Control surface, control horn, linkage or servo damage.</li> <li>• Wire damaged or connections loose.</li> </ul>	<ul style="list-style-type: none"> <li>• Replace or repair damaged parts and adjust controls.</li> <li>• Do a check of connections for loose wiring.</li> </ul>
Controls reversed.	<ul style="list-style-type: none"> <li>• Channels are reversed in the transmitter.</li> </ul>	<ul style="list-style-type: none"> <li>• Do the control direction test and adjust controls for aircraft and transmitter.</li> </ul>
Motor loses power Motor power pulses then motor loses power.	<ul style="list-style-type: none"> <li>• Damage to motor, or battery.</li> <li>• Loss of power to aircraft.</li> <li>• ESC uses default soft Low Voltage Cutoff(LVC).</li> </ul>	<ul style="list-style-type: none"> <li>• Do a check of batteries, transmitter, receiver, ESC, motor and wiring for damage(replace as needed).</li> <li>• Land aircraft immediately and recharge flight battery.</li> </ul>
LED on receiver flashes slowly.	<ul style="list-style-type: none"> <li>• Power loss to receiver.</li> </ul>	<ul style="list-style-type: none"> <li>• Check connection from ESC to receiver.</li> <li>• Check servos for damage.</li> <li>• Check linkages for binding.</li> </ul>

## » Spare parts list

AHRB101	Fuselage	AHRB115	Steering Arm Set
AHRB102	Main Wing Set	AHRB116	Lamp Cover
AHRB103	Vertical Stabilizer	AHRB117	Battery Cover
AHRB104	Horizontal Stabilizer	AHPROP018	Propeller
AHRB105	Cowl	AHDJX001	Motor Amout
AHRB106	Spinner	AHBMX010	Motor Board
AHRB107	LED set	AHDZX003	Motor Shaft
AHRB108	Main Landing Gear Set	AHKVX850	3536-KV850 motor
AHRB109	Linkage Rods	AHESC004	"40A ESC (With 200mm length input cable)"
AHRB110	Supporting Struts	AHSER016	9g digital gear servo positive with 300mm wire
AHRB111	Screws Set	AHSER018	9g digital gear servo positive with 600mm wire
AHRB112	Decal sheet		
AHRB113	Pipe		
AHRB114	Front Landing Gear Set		

## 重要提示：

1. 在组装、调整及飞行前请务必认真阅读产品说明书以熟知产品的特性。请严格按照说明书提示进行飞机的组装、调整及飞行。
2. 模型不是玩具，具有一定的危险性，操作者需要具备一定的飞行经验，初学者请在专业人士指导下操作。
3. 禁止十四岁以下儿童在任何情况下操作、飞行。

## 警告

- ★作为用户，您对本产品的安全操作和维护负全部责任。请始终严格遵照产品指导说明及安全警告操作本产品及其相关配置（例如遥控器、充电器、电池等）。
- ★本产品由无线电遥控器控制，在飞行过程中，可能会受到外界强信号源干扰而导致失控，甚至坠机，因此在飞行过程中务必始终与飞机保持一定的安全距离，避免意外碰撞、受伤。
- ★请勿随意暴露置放模型飞机的电子产品，尤其是电池，存放时请务必保证周围三米之内无易燃易爆物体。
- ★在任何情况下，都务必保证油门杆处于起始位、发射机处于通电状态时，才能连接模型飞机内部的动力电池。
- ★在任何情况下，都不要尝试用手去回收飞行中的模型飞机，必须要等模型飞机降落停稳以后，再进行回收。
- ★请勿在公路、人群、高压线密集区、机场附近及其它法律法规明确禁止飞行的场合飞行。
- ★请勿在雷雨、大风、大雪或者其它恶劣气象环境下飞行。
- ★请勿将相关化工类产品、零部件、电子部件等置于儿童可触及的范围。
- ★请勿将本产品尤其是未经特别设计和保护的电子件暴露于潮湿的环境中，以免造成损坏。
- ★请勿将本品任意处置于口中，以免造成人身伤亡。
- ★请勿在发射机电池低电量的情况下操纵模型飞机。
- ★请勿在配件未充分冷却的情况下触碰或移动。
- ★请勿使用化学制剂擦拭清洁本产品。
- ★务必保证飞机在整个操作过程中始终在视线范围和遥控控制距离内。
- ★务必保证在拆卸飞机之前移除电池。
- ★务必保证所使用的电池是满电状态。
- ★务必保证所使用的所有线束完好无损。

## 飞行前准备

1. 开箱检查包装内物品是否有损坏或遗漏。
2. 通读此飞机说明书以及其相关配置说明书（如遥控器、电池和充电器）。
3. 确保遥控器和使用的电池都是满电状态（请严格遵从配件原厂家说明书）。
4. 遥控器设置（请严格遵从遥控器厂家的说明书）。
5. 严格遵从本说明书指导组装飞机，确保螺丝、卡扣、夹头、插销等紧固件全部安装到位，舵角摇臂连接可靠。（暂不安装螺旋桨）。
6. 安装满电状态的电池，并通过挪动电池在电池舱里的前后位置，调整飞机重心（CG）至说明书推荐位置。
7. 通电测试确保所有的操纵钢丝活动自如。
8. 通电测试确保所有的舵面正确响应遥控器输入指令。
9. 根据所需调整舵面行程（首飞推荐使用出厂设置行程）。
10. 桨机安装螺旋桨，确保螺旋桨组件安装到位，且转动方向正确。
11. 寻找一个安全空旷远离建筑和人群的场地，根据场地实际情况，做具体飞行计划。

## 飞机简介

蓝箭 1400mm 空巡 (SKY CRUISER) 满足玩家对训练机的要求和期待, 稳定、好飞、易操控。

特征:

- 出厂配置高品质 40A 电调、3536-KV850 电机, 6 个高敏度 9g 舵机精准控制襟翼、副翼、升降舵和方向舵。
- “前三点式”起落架, 飞机着陆时易操控, 地面运动稳定性好, 滑行中不易偏转和侧翻。
- CNC 加工金属前起落架——内置 CNC 金属减震, 外部使用像真塑胶件。
- 5 个高亮 LED 航灯分布于左右翼尖 (左红右绿各 1 个, 常亮), 左机翼 (白灯 X2, 常亮) 和垂尾 (红灯 X1, 闪烁), 给飞行增加趣味性。
- 超大尺寸驾驶舱覆盖茶色透明吸塑座舱, 附带飞行员和像真仪表盘, 给飞行增加趣味性。
- 功能性襟翼 (可活动)。
- 塑胶材质翼撑, 有效增加机翼强度, 便利高速飞行。
- 像真装饰天线。
- 高效率 11 寸三叶桨。
- EPO 泡沫材质, 轻量化、高刚性。
- 颜值高、性能好、飞行稳定、起落架结实, 适合新手入门和进阶飞行练习。

## 目录

飞行前准备 .....	14
目录 .....	15
产品包装清单 .....	15
飞机简介 .....	15
产品基本参数 .....	15
组装过程 .....	16
电池安装 .....	20
接收机连接示意图 .....	20
重心 .....	20
重要产品相关信息 .....	21
电调说明 .....	21
遥控器设置 .....	21
舵面测试 .....	22
夹头安装方式 .....	23
舵角和舵机摇臂安装 .....	23
舵面行程 .....	23
故障检修指导 .....	24
配件列表 .....	24

## 产品基本参数

翼展	1,410mm/55.5in
机身长	1,100mm/43.3in
飞行重量	~ 1,520g
电机	3536-KV850
翼载荷	56.3g/d m <sup>2</sup>
翼面积	27d m <sup>2</sup>
电调	40A
舵机	9g Servo x 6
推荐电池	Li-Po 11.1V 2200mAh 25C

**! 注意:** 此处各项参数, 均是使用本公司配件测试得出, 如果使用他厂配件, 会有所差异。使用他厂配件时所产生的问题, 我司将无法给予技术支持。

## 产品包装清单

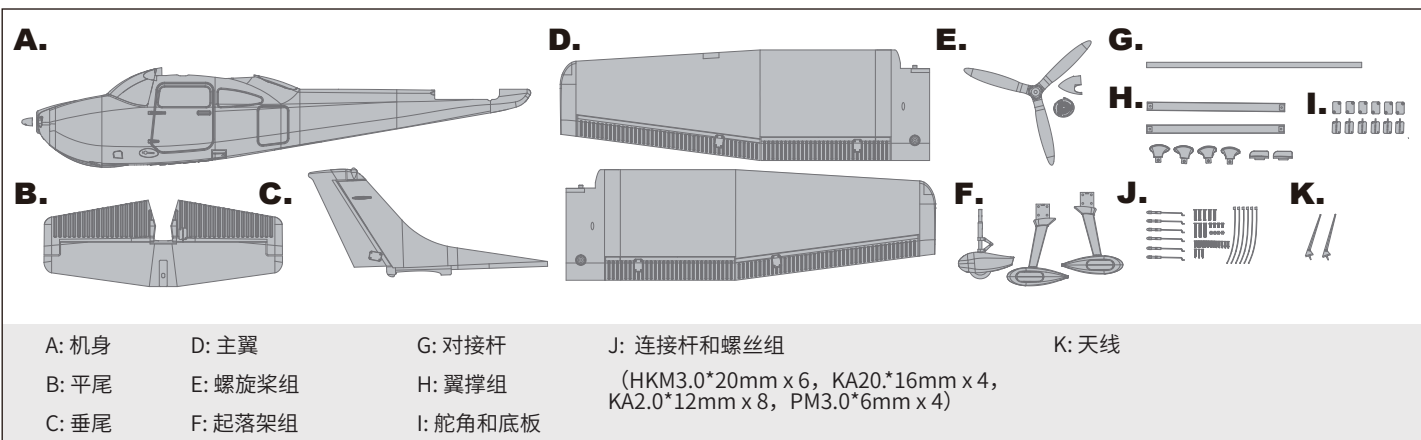

## 起落架安装

1. 将前起落架对准机身底部安装孔位装入。
2. 使用所附螺丝（PM2.0\*8mm x 1）将前起落架固定到位。注意，所附螺丝应从头罩的进气口方向装，如图所示，以便保持贴纸的完整性。

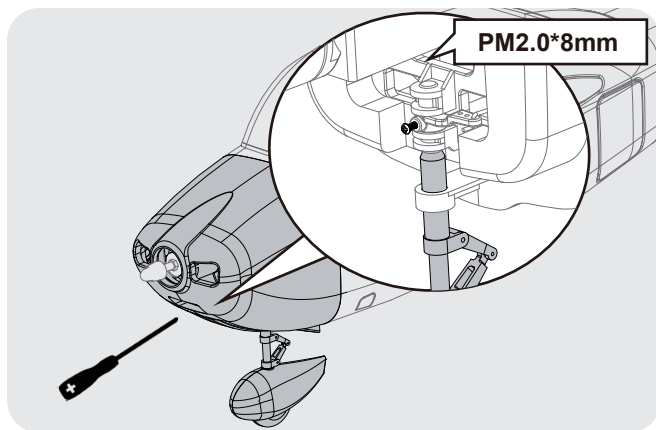
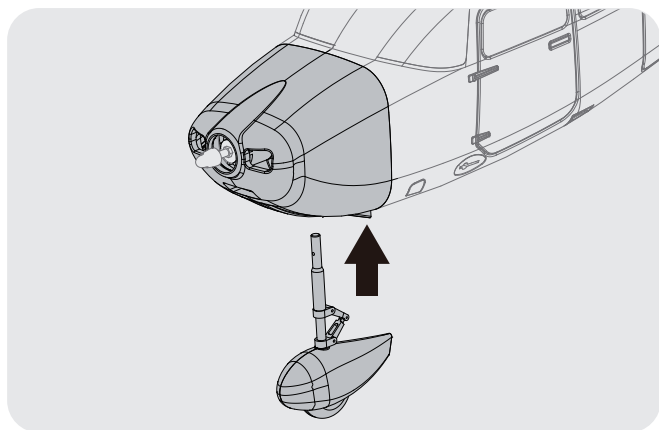

3. 保持机身底部向上，安装主起落架至机身底部相对应槽位，并使用所附螺丝固定到位（HKM3.0\*20mm x 4）

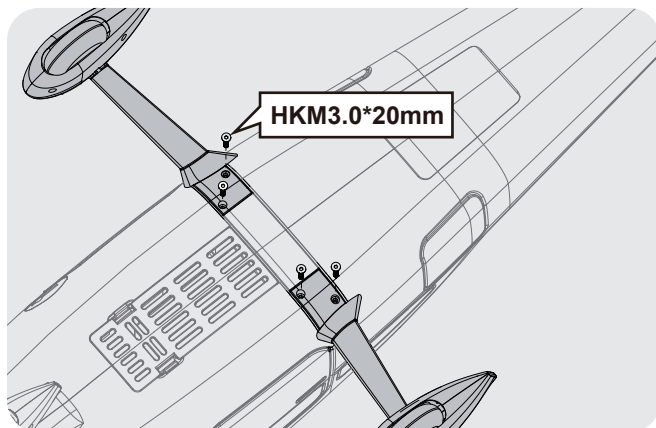

## 机翼安装

1. 从所附配件包中取出襟翼和副翼的舵角和底部垫片，使用所附螺丝将舵角和底部垫片固定在襟翼舵面和副翼舵面槽位里。注意，副翼舵面固定螺丝 KA2.0\*12mm x 2pcs, 襟翼舵面前后固定位置使用的螺丝尺寸不同, 前（机头方向）: KA2.0\*16mm x 1pc, 后（机尾方向）: KA2.0\*12mm x 1pc。
2. 如图所示，将所附连接钢丝分别安装在舵机摇臂和舵角孔位中。

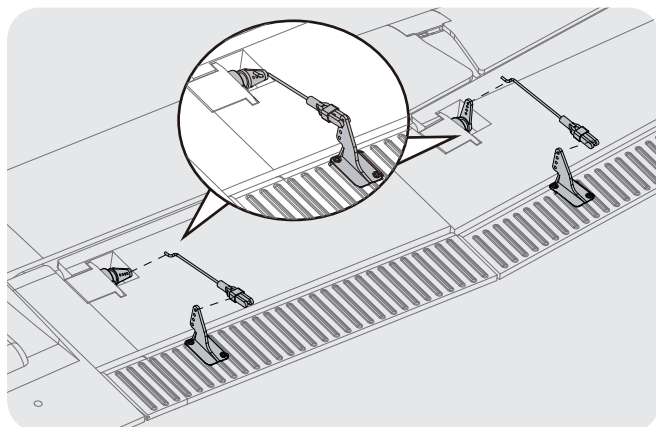
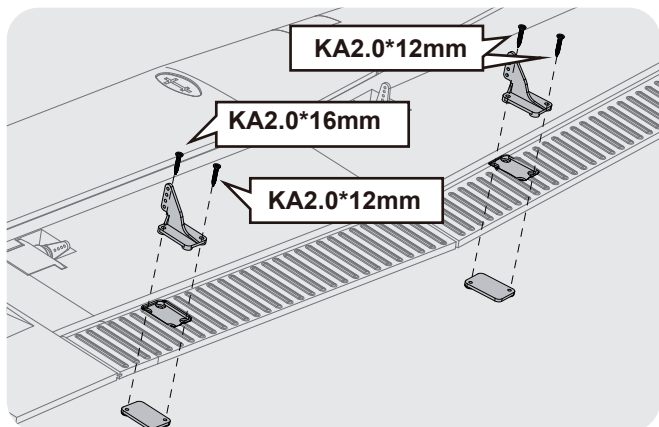

3. 从所附配件包中取出机身翼撑底座（底座设有防呆模式，可防止装反），在图示机身槽位和翼撑底座的接触面均涂上泡沫胶，然后对准粘牢。

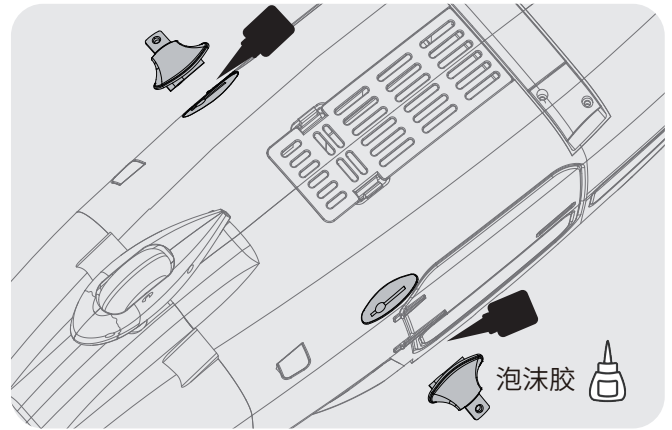

4. 从所附配件包中取出机翼翼撑底座（底座设有防呆模式，可防止装反），在图示机翼槽位和翼撑底座的接触面均涂上泡沫胶，然后对准粘牢。

5. 从所附配件包中取出像真天线，在图示机翼槽位和天线底部的接触面均涂上泡沫胶，然后对准粘牢。

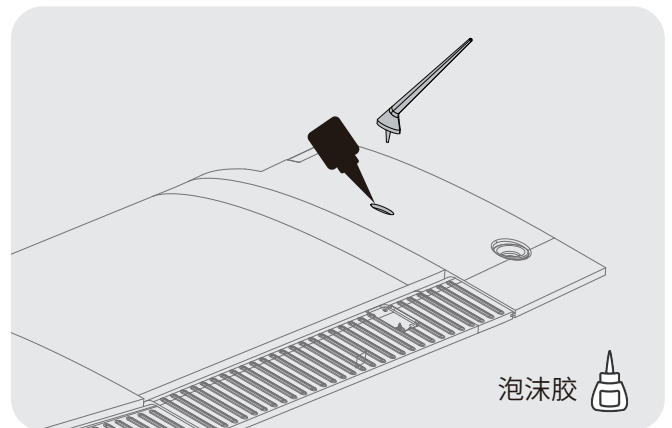
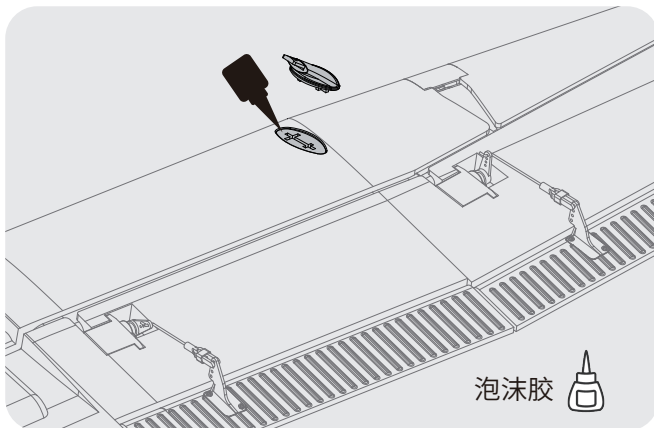

6. 使用所附对接管，安装左右两侧机翼。

7. 使用所附两根 2Y 线连接副翼舵机线和襟翼舵机线（请注意对应通道贴标连接），1 根 3Y 线连接 LED 延长线，然后使用扎带将线束扎齐，并将线束从机身上方的孔位顺到机身底部，以便连接接收机。使用所附螺丝（HKM3.0\*20mm x 2）将主翼固定至机身。

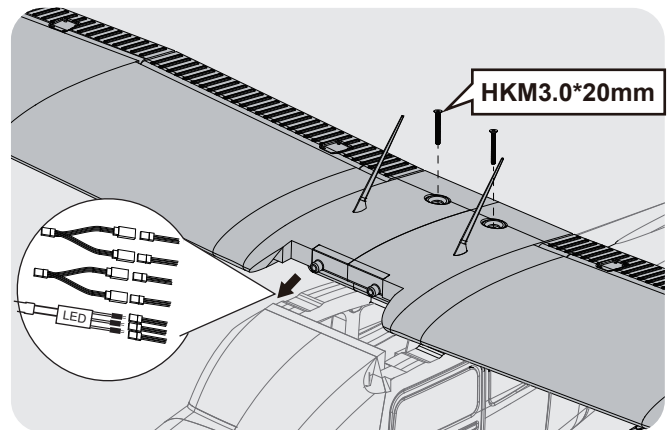
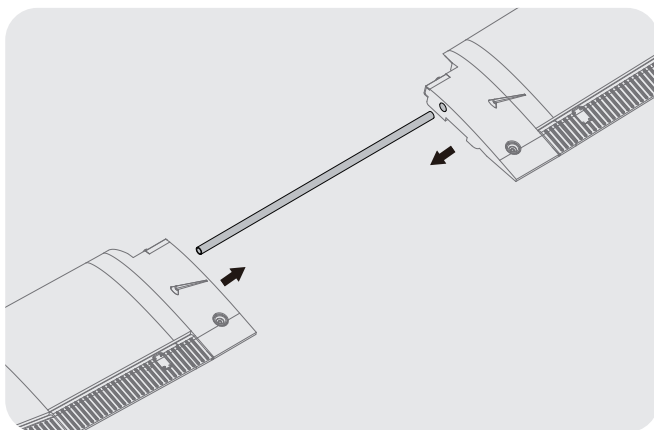

8. 将翼撑杆分别安装至机身底座和主翼底座，并使用所附螺丝（PM3.0\*6mm x 4）和螺母固定。

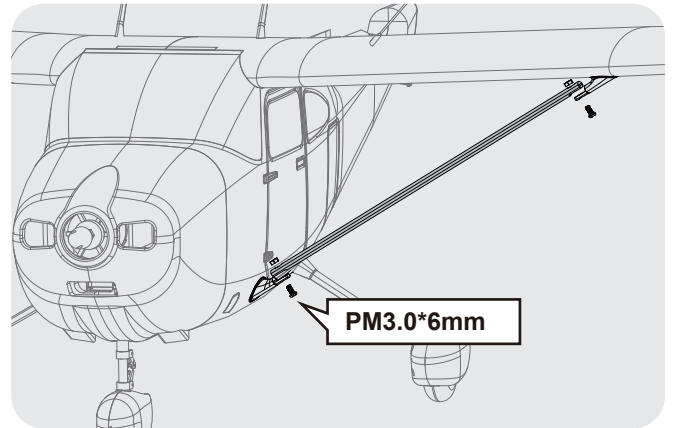

### 平尾和垂尾的安装

1. 从所附配件包中取出平尾的舵角和底部垫片，使用所附螺丝（KA2.0\*16mm x 2pcs）将舵角和底部垫片固定在平尾舵面槽位里。

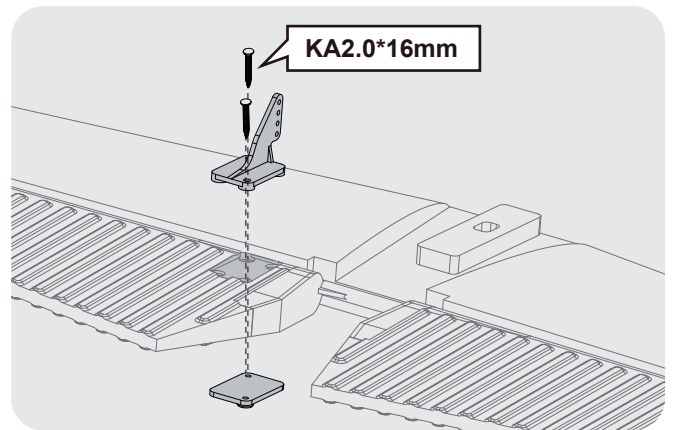

2. 从所附配件包中取出垂尾的舵角和底部垫片，使用所附螺丝（KA2.0\*12mm x 2pcs）将舵角和底部垫片固定在垂尾舵面槽位里。

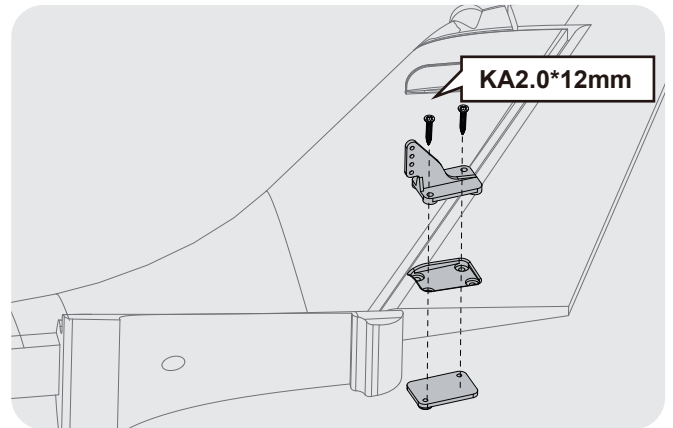

3. 引导机身尾部的延长线穿过平尾孔位，将泡沫胶分别涂于平尾和机身尾部槽位，安装平尾至机身。对接延长线与垂尾 LED 灯线，将泡沫胶分别涂于垂尾与平尾接触面，粘贴垂尾至平尾。

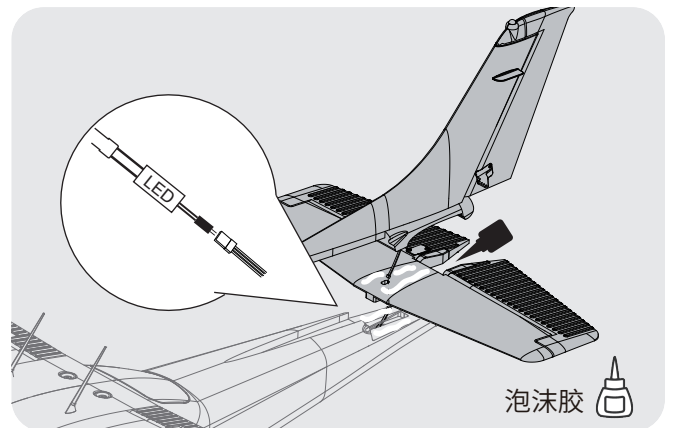

## 《—— 组装过程 ——》

4. 安装平尾连接钢丝至平尾舵角
5. 安装垂尾连接钢丝至垂尾舵角

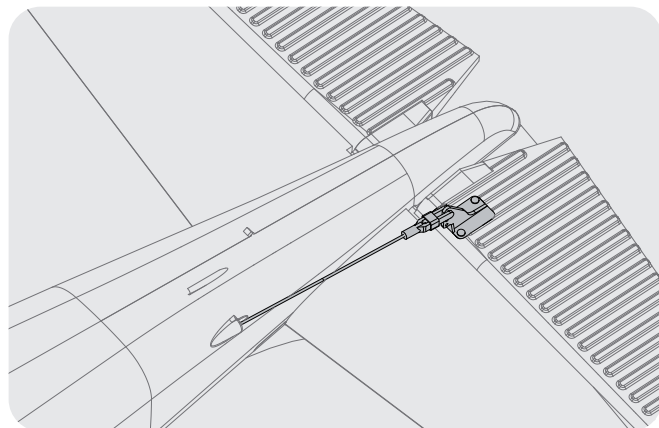
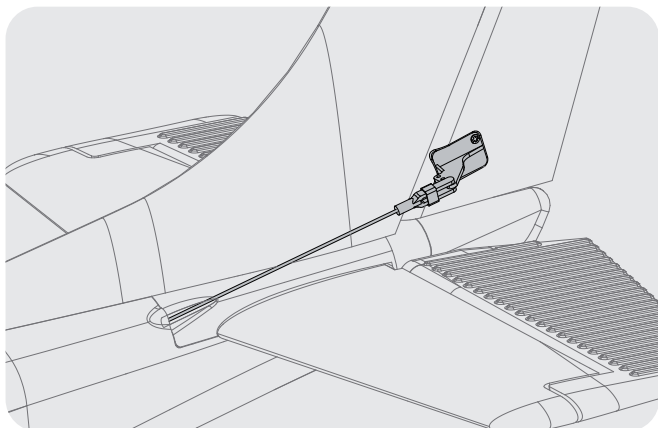

6. 将泡沫胶分别涂于垂尾像真件和垂尾两侧安装槽位的接触面，安装像真件至垂尾，如图所示。

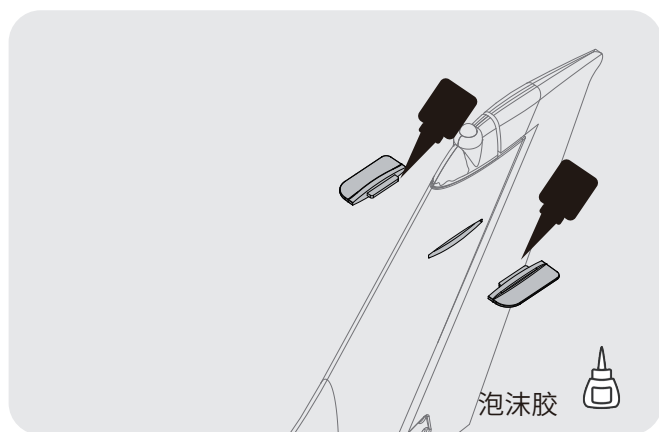

### 螺旋桨安装

1. 如图所示，依序安装螺旋桨和桨罩组件。

注意：机翼后方视角下，电机应保持顺时针旋转。

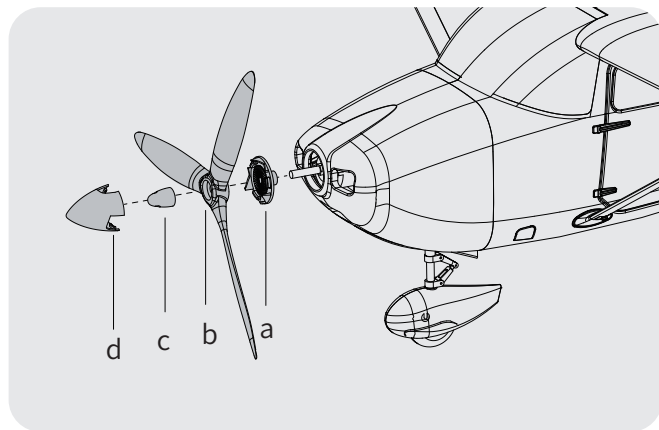

## 电池安装

如图所示，安装厂家推荐型号电池至电池舱，使用所附魔术带或魔术贴固定。

### 注意：

1. 电池与电调连接前，务必确定油门杆处于低位。
2. 启动油门前，务必确定没有任何人或物体处于螺旋桨的转动直径以内。
3. 由于不同电池厂家生产的电池重量有轻微差异，需要调整电池在舱内的前后位置来平衡飞机的重心位置。

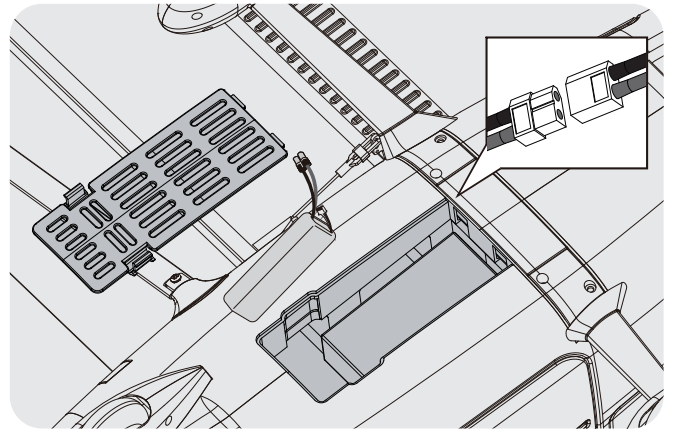

## 接收机连接示意图

以 Futaba 遥控器为例，请按照图示顺序——连接接收机通道，其他通道可接入襟翼信号线或 LED 灯信号线，随后妥善固定接收机。

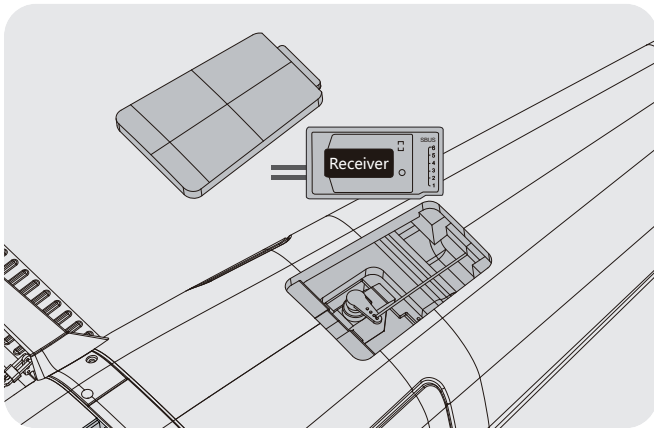

		Receiver
副翼	1	Channel-1 —Aile
平尾	2	Channel-2 —Elev
油门	3	Channel-3 —Thro
垂尾	4	Channel-4 —Rudd
起落架	5	Channel-5 —Gear
襟翼	6	Channel-6 —Flap

## 重心

本产品的重心在机翼前缘向后 60mm 的位置。玩家需要通过移动电池在电池舱里的前后位置或者使用配重块来调整重心。请务必确保，在调整飞机重心的时候，飞机处于组装完毕待飞的状态。

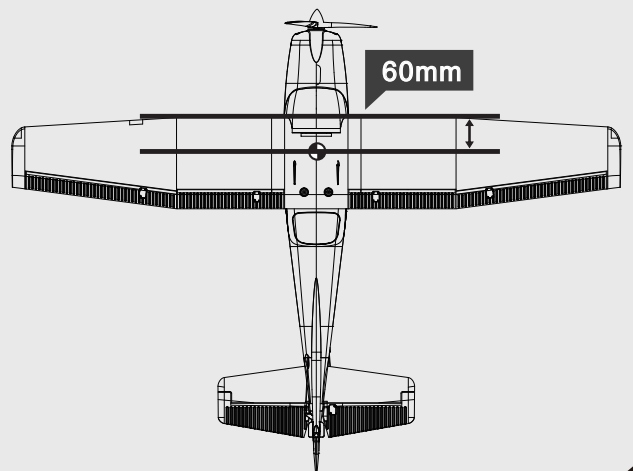

1. 此模型附带的电调 (ESC) 具有安全启动功能。如果电机电池已连接到电调, 但油门杆不在低油门或关闭位置, 则电机将不会启动, 直到将油门杆移动到低油门或关闭位置。一旦油门杆移动到低油门或关闭位置, 电机将发出一系列蜂鸣声。相同曲调的多个蜂鸣声表示电调已检测到电池的单片节数。蜂鸣声的数量等于电池的单片节数数量。电机现在已经准备就绪, 并将在移动油门杆时启动。
2. 电机和电调器已预先连接, 并且电机的旋转方向应该是正确的。如果出于任何原因电机旋转方向错误, 只需交换电机三根导线中的两根即可更改旋转方向。
3. 电池的选择和安装: 我们推荐使用 11.1V 2200mAh 25C 电池。如果玩家选购其它电池, 我们建议所选电池容量不低于推荐电池。玩家选购的电池在容量、尺寸和重量上需近乎与我们推荐的电池相同, 这样在电池装入机身以后才不会对飞机重心产生太大的影响。

## 电调说明

注意: 为了让电调适应你的遥控器油门行程, 在首次使用本电调或更换其他遥控器使用时, 均应重新设定油门行程。

油门行程设定说明:

1. 开启遥控器, 将油门打到最高点;
2. 将电调接上电池, 等待 2 秒;
3. “哔 - 哔 -” 油门最高点, 确认声音;
4. 将油门推到最低等待 1 秒;
5. N 声短鸣音表示锂电节数;
6. “哔 -” 油门最低点, 确认声音;
7. 系统准备就绪可以起飞。

正常使用开机过程说明:

1. 开启遥控器, 将油门打到最低点;
2. 电调接上电池, 鸣叫提示音符 “123”, 表示上电正常;
3. 发出 N 声短鸣音, 表示锂电池节数;
4. 自检 OK, 发出长鸣音 “哔——” 系统准备就绪;
5. 推油门可随时起飞。

## 遥控器设置

请参考遥控器原厂家说明书。

## 舵面测试

在飞机组装完成以后，在计划飞行之前，需要使用遥控器测试每个舵面的工作情况，确保摇杆动作与各个舵面动作的对应关系如下图所示：

**注意：**在舵面调试中，请务必拆下螺旋桨，以免电机意外启动发生事故。

### 副翼

副翼摇杆  
向左运动

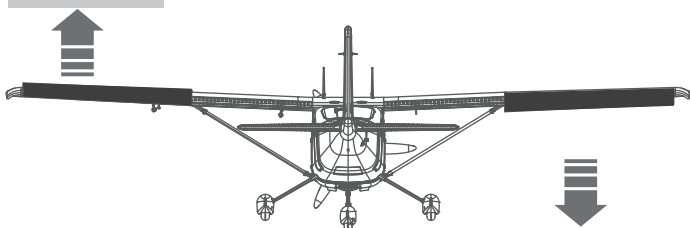

副翼摇杆  
向右运动

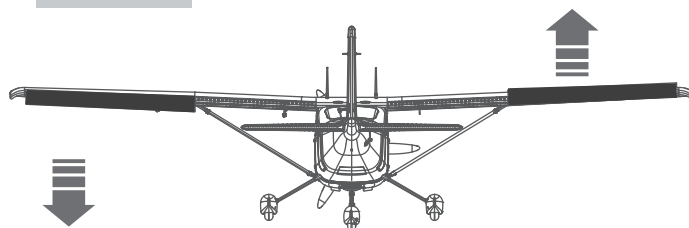

### 升降舵

升降摇杆  
向下运动

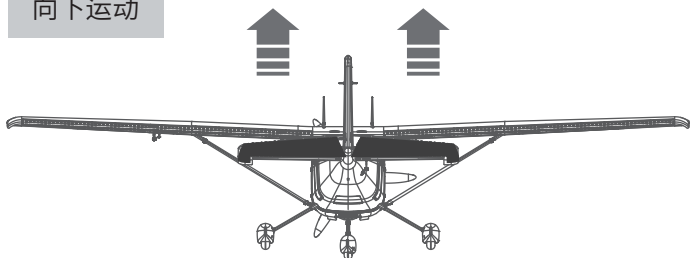

升降摇杆  
向上运动

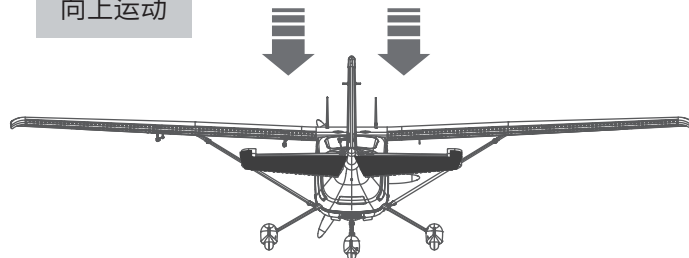

### 方向舵

方向摇杆  
向左运动

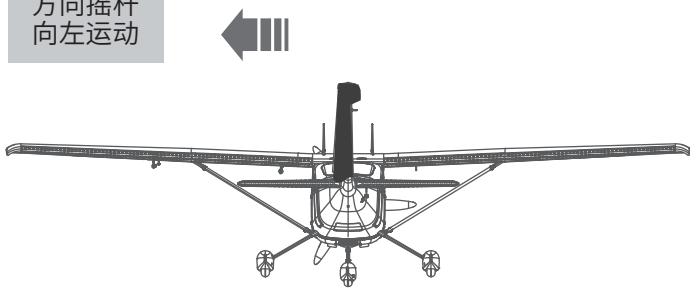

方向摇杆  
向右运动

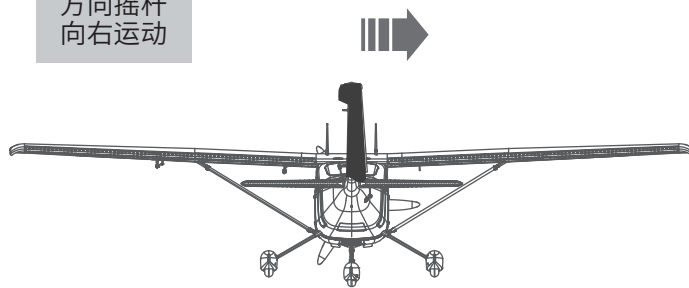

## 夹头安装方式

1. 保证舵机为回中状态，将连接杆夹头调整到合适位置。
2. 将 O 型圈移开，打开夹头，将夹头安装到舵角孔位。
3. 将 O 型圈移回相应位置，锁紧夹头。

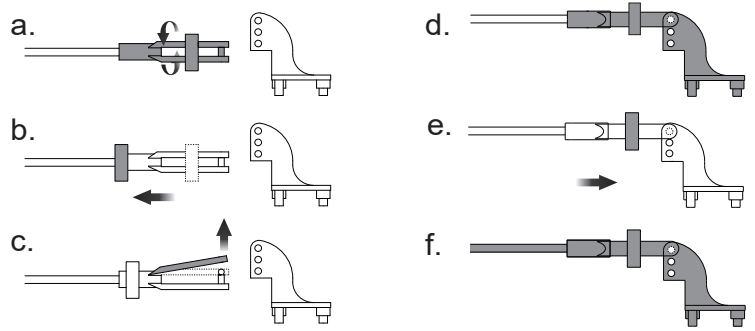

## 舵角和舵机摇臂安装

图示是出厂设置，首飞建议直接使用出厂设置，完成首飞以后，根据个人情况以及对模型飞机的熟知程度自行调整。

	舵角	摇臂	大舵面	
平尾				
垂尾			小舵面	
副翼				
襟翼				

## 舵面行程

本产品舵面行程参数如右图所示：

请注意，舵量越大，模型飞机的动作响应越快，动作幅度越大。首飞建议使用小舵量。然后根据个人情况以及对模型飞机的熟知程度调整舵量。

	大	小
方向舵	10mm 左 / 右	6mm 左 / 右
升降舵	15mm 上 / 下	10mm 上 / 下
副翼舵	9mm 上 / 下	5mm 上 / 下

问题	问题原因	解决方式
油门推杆无响应，但舵机有响应	— 电调未连接电机 — 油门通道反向	— 降低油门推杆和油门微调设定 — 反过来重新装油门通道
桨的噪音过大或者震动过大	— 桨罩、桨、电机、电机架坏了 — 桨或者桨罩的小部件松动了 — 桨装反了	— 更换损坏的配件 — 把桨、桨夹和桨罩的小部件拧紧 — 反过来重新装桨
飞行时间变短，飞机无力	— 电池电量低 — 桨装反了 — 电池坏了	— 重新给电池充电 — 依照电池说明书更换新的电池
飞舵面不动，或者动作响应较慢	— 舵面、舵角、连接杆、舵机坏了 — 连接线坏了或者接头松了	— 更换或者维修坏了的配件 — 检查所有连接线，确保所有接头无松动现象
舵面反向	— 遥控器发射机通道反向	— 检查通道控制（舵面）方向，调试飞机舵面和遥控器的舵面控制杆
电机无力	— 电机或电池坏了 — 电调用了不合适的低压保护装置	— 检查电池、发射机、接收机、电调、电机是否有损坏（如有，请及时更换） — 立刻操控飞机降落，重新给电池充电
接收器的 LED 灯慢闪	— 接收器低电量	— 检查电调和接收器之间的连接 — 检查舵机是否受损 — 检查连接杆是否安装到位

配件列表

AHRB101	机身	AHRB115	转向摇臂组
AHRB102	主翼	AHRB116	灯罩
AHRB103	垂尾	AHRB117	电池盖
AHRB104	平尾	AHPROP018	桨
AHRB105	机头罩	AHDJX001	电机架
AHRB106	桨罩	AHBMX010	电机板
AHRB107	LED灯组	AHDZX003	电机轴
AHRB108	主起落架组	AHKVX850	3536-KV850电机
AHRB109	连接杆	AHESC004	40A电调(200mm线长)
AHRB110	支撑杆	AHSER016	9g塑胶数码正向舵机L=300mm
AHRB111	螺丝组	AHSER018	9g塑胶数码正向舵机L=600mm
AHRB112	贴纸		
AHRB113	对接管		
AHRB114	前起落架组		