

# 1450mm Tecnam-2010 Operating Manual

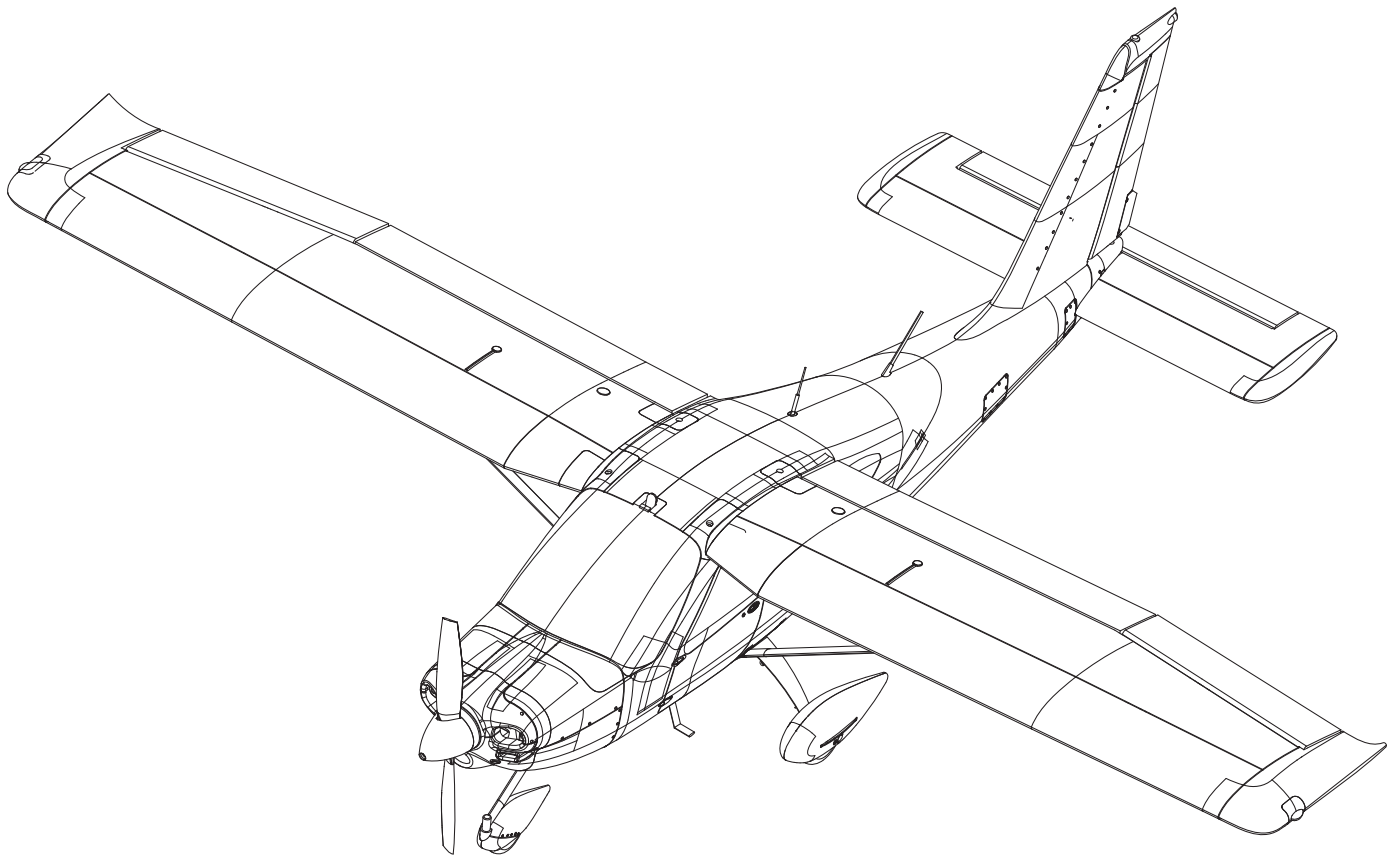

**WARNING:** This manual contains important information that will help you maintain and operate your model aircraft in a reliable and safe manner. Please read the instructions and warnings carefully prior to assembly, setup or use.

As this model aircraft is a sophisticated hobby product, it must be flown with safety and common sense in mind, failure in doing so may result in injury or property damage. This product is not intended for use by children without direct adult supervision.

## Safety precautions and Warnings

As the user, you are solely responsible for the safe operation and maintenance of this product. Follow the directions and warnings listed in this manual, as well as that of supporting equipment (chargers, batteries etc.) and always use common sense.

### **This is not a toy. Not for children under 14 years of age.**

- ★ Always operate your model in an open area away from buildings, cars, traffic or people. Never operate near people—especially children who can wander unpredictably. Never operate in populated areas for any reason, where injury or damage can occur.
- ★ Always keep a safe distance in all directions around your model to avoid collisions or injury. This model is controlled by a radio signal subject to interference from many sources outside your control. Interference can cause momentary loss of control.
- ★ Never catch the aircraft while it is in flight, the structure of the fuselage was not designed and protected for this purpose.
- ★ Never operate your model in bad weather, including in excessively windy or precipitating conditions.
- ★ Never operate your model with low transmitter batteries.
- ★ Keep your throttle quadrant in its lowest position prior and after every flight. Use the throttle cut function if able.
- ★ Always use fully charged batteries and move batteries before disassembly.
- ★ Avoid water exposure to all equipment not specifically designed and protected for this purpose.
- ★ Avoid cleaning this product with chemicals.
- ★ Never lick or place any part of your model in your mouth as it could cause serious injury or even death.
- ★ Keep all chemicals, small parts and anything electrical out of the reach of children.

# Introduction

Explore new heights with the Arrows Hobby 1450mm Tecnam-2010

Designed from the ground-up as a beginner-friendly aircraft, the Arrows Hobby Tecnam-2010 is easy to build and easy to fly.

**Easy to build:** Thanks to the modular construction of the airframe, the aircraft is ready for flight with the installation of only a few screws. Remove the screws and the aircraft easily comes apart for transportation and storage. **Easy to fly:** Light wing loading and a high-lift airfoil design gives the aircraft highly predictable flight characteristics. With the pre-installed Vector system, the Tecnam-2010 is one of the most forgiving aircraft on the market, while retaining aerobatic performance for advanced pilots looking for a relaxing weekend flyer. The nose wheel and rudder are controlled by independent servos- allowing for easy ground handling.

**Power:** Power comes courtesy of a high-quality 3536-850KV motor and 30A ESC (Arrows recommends a 11.1V 2200mAh 25C flight battery). when paired with the highly efficient 11x7 propeller and proper throttle management, expect flight times of up to 15 minutes! **Advanced features:** Built using durable EPO material and equipped with rugged plastic wing struts, the Tecnam-2010 will stand up to a surprising amount of wear and tear. A latch-type battery cover makes changing batteries a painless experience.

Floats are included for pilots who want to explore the thrills of floatplane flying!

Whether you're a beginner or an advanced pilot, the Arrows Hobby 1450mm Tecnam-2010 is the perfect aircraft to have in your fleet!

## Features:

- Electronics: 3536-850KV motor, 30A ESC, 9g digital servos
- Functional flaps, full-flying horizontal stabilizer for excellent low speed handling
- Floats included as standard
- Takes off in less than 5 m
- Oversized battery compartment
- Metal shock-absorbing landing gear
- Bright navigation lights
- Latch type battery bay cover
- Screw together assembly (excluding antenna)
- Made from durable EPO material

## Table of contents

Introduction .....	3
Specifications .....	3
Kit contents .....	3
Model Assembly .....	4
Battery installation .....	8
Receiver diagram .....	8
Preflight check .....	8
Control horn and servo arm settings .....	9
Center of gravity(CG) .....	10
Before flying the model .....	10
Flying course .....	11
Trouble shooting .....	12
Spare parts list content .....	12

## Specifications

<b>Wingspan</b>	<b>1450mm (57.1in)</b>
<b>Overall length</b>	<b>1110mm (43.7in)</b>
<b>Flying weight</b>	<b>~ 1280g</b>
<b>Motor size</b>	<b>3536-KV850</b>
<b>Wing load</b>	<b>42.7g/dm<sup>2</sup> (0.09oz/in<sup>2</sup>)</b>
<b>Wing area</b>	<b>30dm<sup>2</sup> (464sq.in)</b>
<b>ESC</b>	<b>30A</b>
<b>Servo</b>	<b>9g Servo x 7</b>
<b>Recommended battery</b>	<b>11.1V 2200mAh 25C</b>

## Kit contents

Before assembly, please inspect the contents of the kit. The photo below details the contents of the kit with labels. If any parts are missing or defective, please identify the name or part number (refer to the spare parts list near the end of the manual) then contact your local shop.

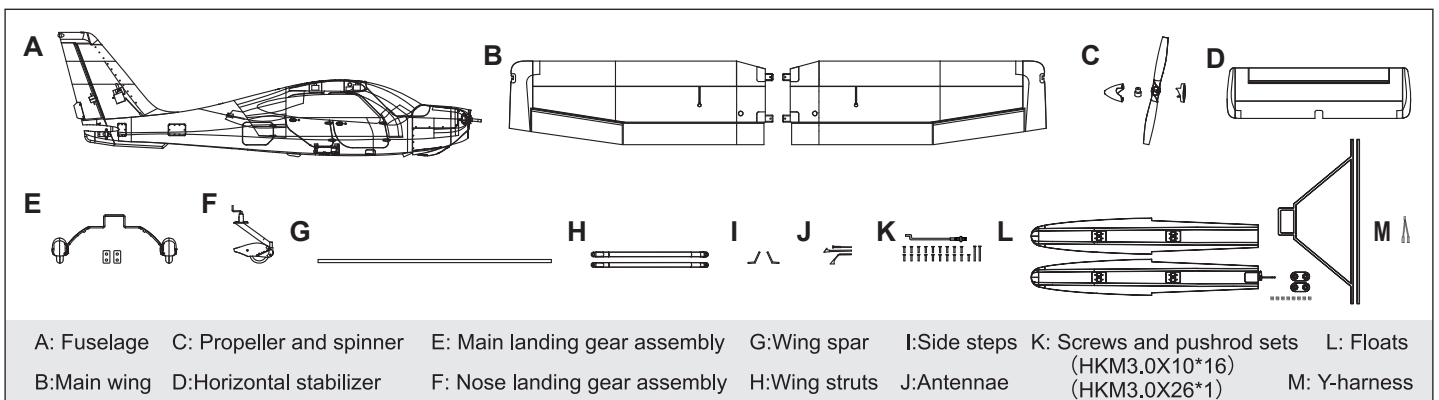

### Main Wing installation

1. Install the wing spar into the fuselage cutout.
2. Slide the wing halves onto the wing spar.

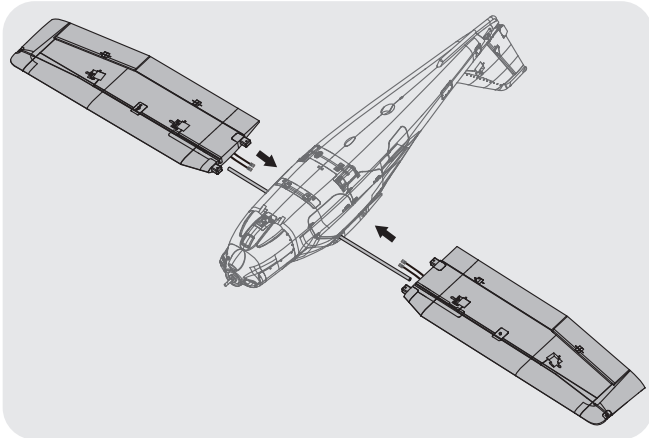

3. Run the aileron wire harness, flaps and lighting cables into the fuselage and connect using a Y connector.
4. Secure the wing halves onto the fuselage using the included screws. Make sure not to over tighten the screws.

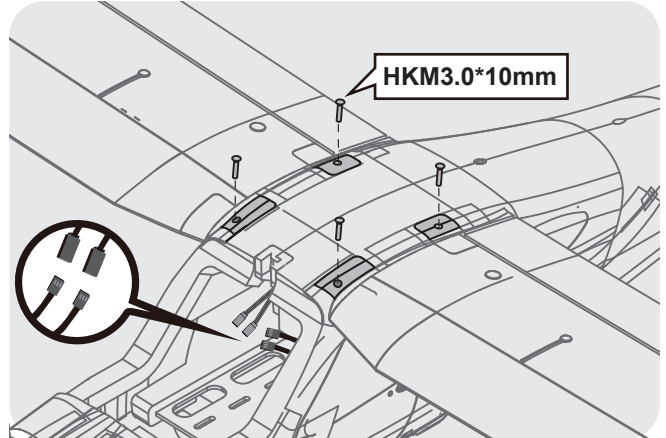

5. Install the wing struts, making sure that they are facing the right orientation.
6. Secure the wing struts using body clips.

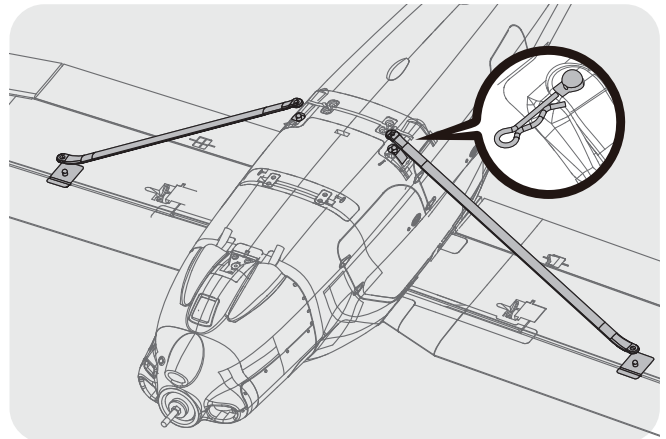

### Horizontal stabilizer installation

1. Install the horizontal stabilizer into the fuselage slot as shown in the picture.

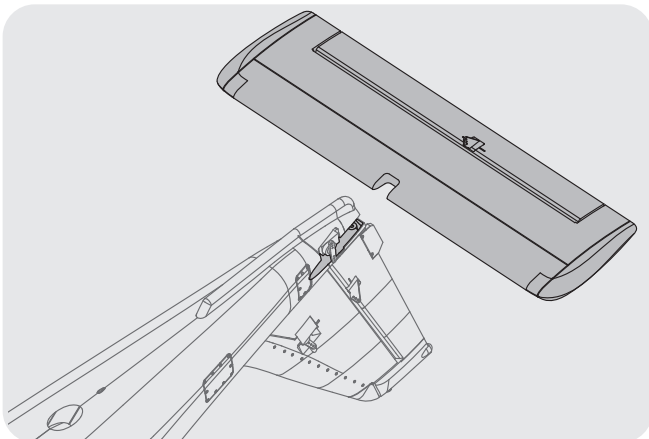

2. Move the rudder control surface to one side, this will help with the alignment of the final screw.  
Note: be careful not to over tighten the screws.

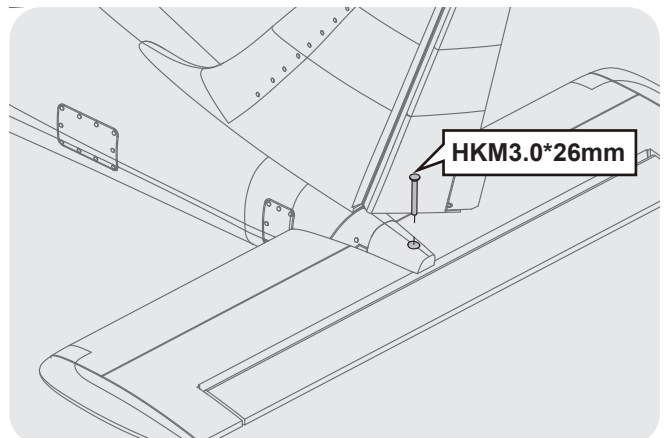

## Push rods and control arm installations

1. With the elevator servo centered and in its neutral position, connect the push rod and clevis onto the elevator control horn.

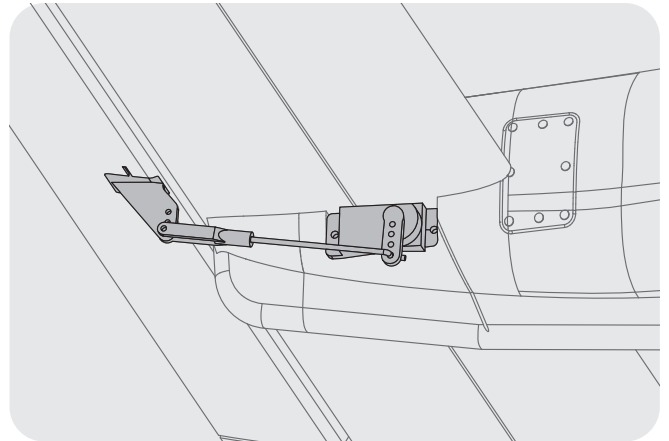

## Landing gear installation

1. Install the landing gear assembly onto the aircraft making sure that the landing gear is orientated correctly.  
2. Secure the landing gear assembly using the retainers and screws as shown in the picture.

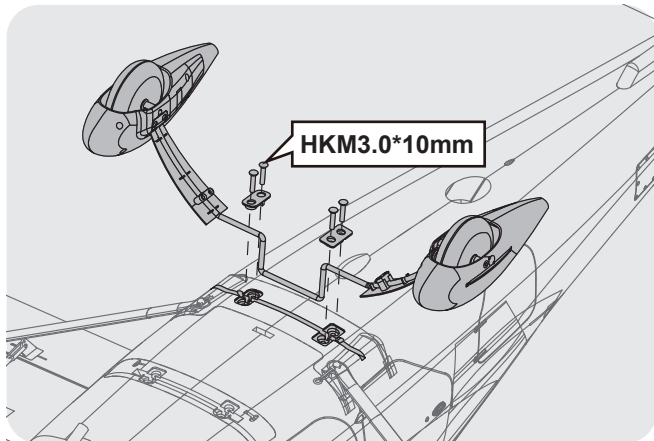

3. Install the nose landing gear into its slot, ensuring that the push rod is linked with the control horn.  
4. Secure the nose landing gear with screws.

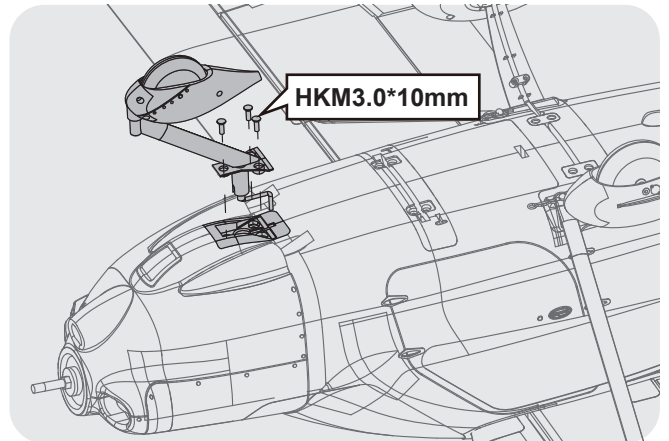

## Side step installation

1. Apply glue to the location shown on the photo and adhere the side steps onto the fuselage.

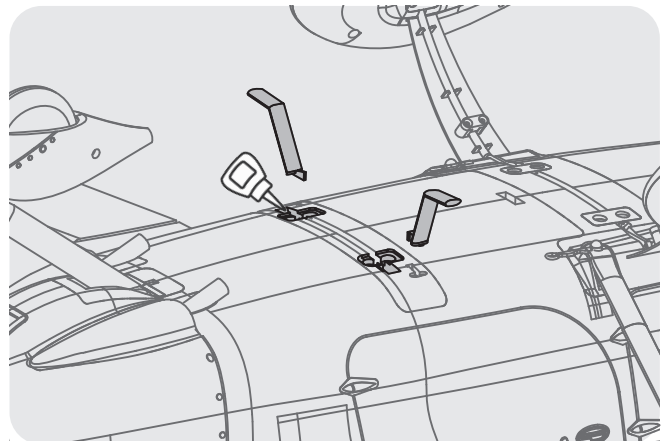

## « Model assembly

### Antenna installation

1. Apply glue to the location shown on the photo and adhere the antennae onto the fuselage.

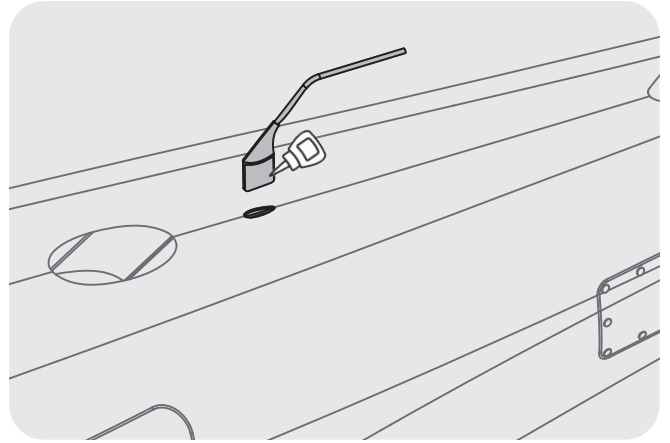
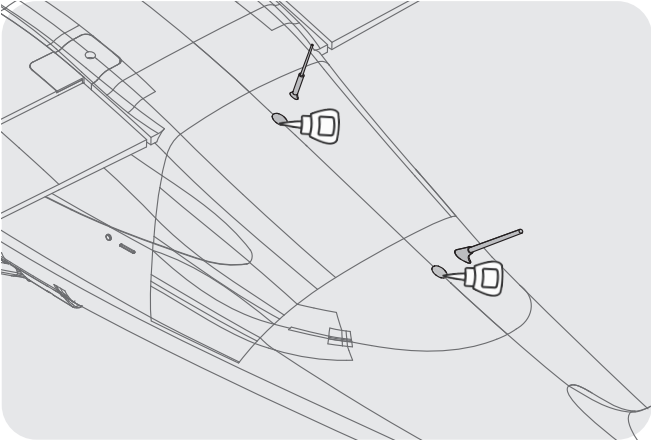

### Propeller and spinner installation

1. Install the propeller and spinner the order shown, be careful not to over tighten the bolt.

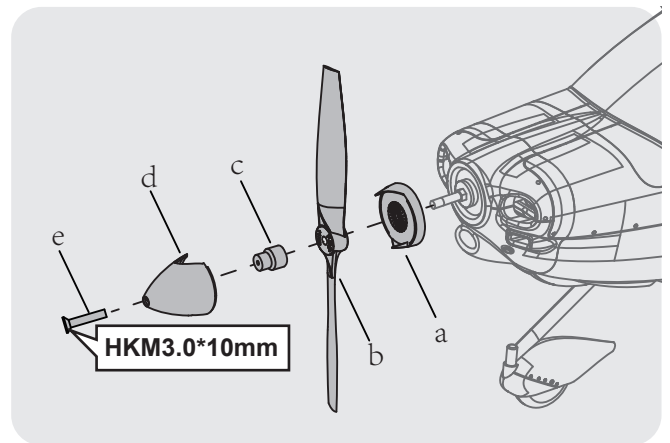

### Installation of floats

1. Assemble the float struts to the plastic holder as shown and secure the struts with screws.

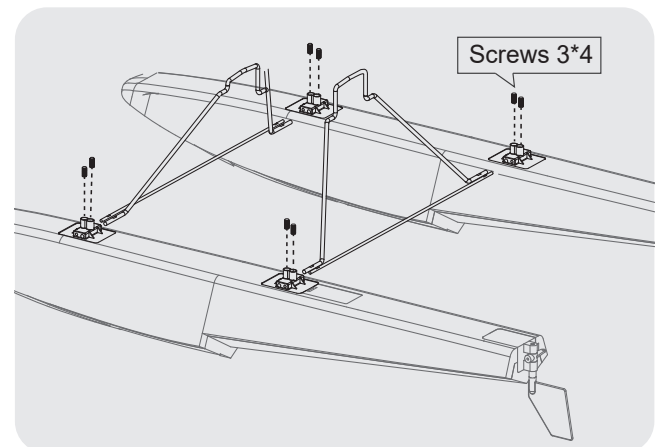

2. Secure the float set onto the bottom of fuselage using the included plastic parts and screws as shown.  
Notice: The connectors on both side should be attached precisely and firmly.

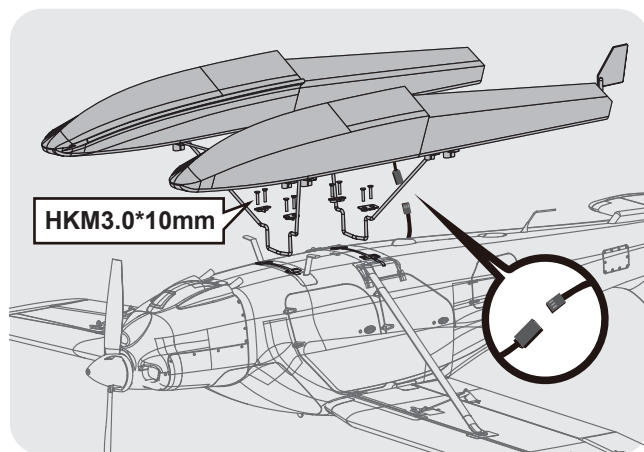

## «—— Battery installation

1. Remove the battery hatch.
2. Remove the hook and loop tape from the fuselage. Apply the looped surface to the battery.
3. Install the battery into the fuselage- securing it with the preinstalled battery straps.

*Note: The weight of each battery may vary due to different manufacturing techniques. Move the battery fore or aft to achieve the optimal center of gravity.*

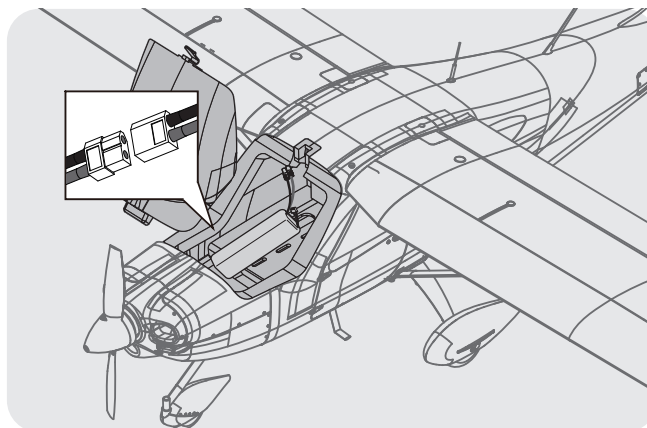

## «—— Receiver diagram

The cables from the servo connector board should be connected to your receiver in the order shown. Note that the LEDs can be powered by any spare channel on the receiver.

Tuck the wire leads into the recessed cavity towards the rear of the battery hatch.

		Receiver
Aileron	1	Channel-1 — Aile
Elevator	2	Channel-2 — Elev
Throttle	3	Channel-3 — Thro
Rudder	4	Channel-4 — Rudd
Spare	5	Channel-5 — Spare
Flap	6	Channel-6 — Flap

## «—— Preflight check

### Important ESC and model information

1. The ESC included with the model has a safe start. If the motor battery is connected to the ESC and the throttle stick is not in the low throttle or off position, the motor will not start until the throttle stick is moved to the low throttle or off position. Once the throttle stick is moved to the low throttle or off position, the motor will emit a series of beeps. Several beeps with the same tune means the ESC has detected the cells of the battery. The count of the beeps equals the cells of the battery. The motor is now armed and will start when the throttle is moved.
2. The motor and ESC come pre-connected and the motor rotation should be correct. If for any reason the motor is rotating in the wrong direction, simply reverse two of the three motor wires to change the direction of rotation.
3. The motor has an optional brake setting. The ESC comes with brake switched off and we recommend that the model be flown with the brake off. However, the brake could be accidentally switched on if the motor battery is connected to the ESC while the throttle stick is set at full throttle. To switch the brake off, move the throttle stick to full throttle and plug in the motor battery. The motor will beep one time. Move the throttle stick to low throttle or the off position. The motor is ready to run and the brake will be switched off.
4. Battery Selection and Installation. We recommend the 11.1V 2200mAh 25C Li-Po battery. If using another battery, the battery must be at least a 11.1V 2200mAh 25C battery. Your battery should be approximately the same capacity, dimension and weight as the 11.1V 2200mAh 25C Li-Po battery to fit the fuselage without changing the center of gravity significantly.



## transmitter and model setup

After assembly and prior to your first flight, make sure all control surfaces respond correctly to your transmitter by referring to the diagram below.

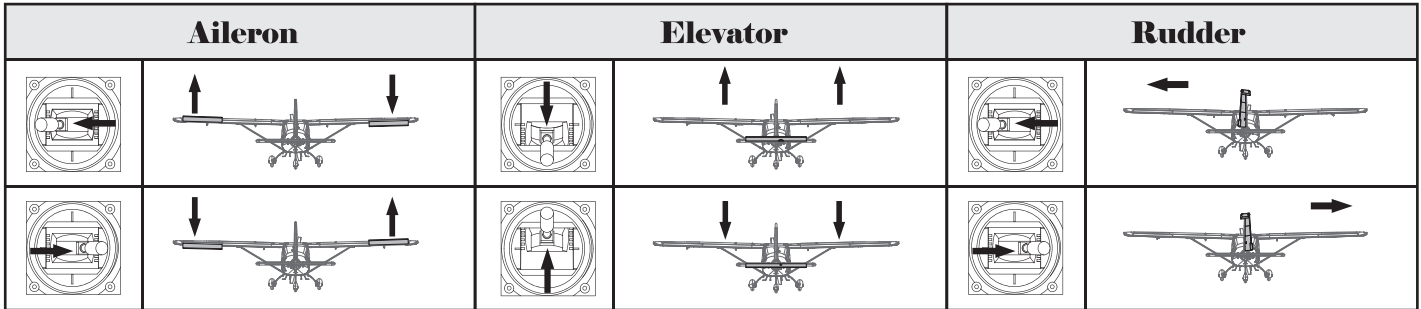

## Control throws

The suggested control throw setting for the 1450mm Tecnam-2010 are as follows (dual rate setting):

Tips: The maiden flight should always be flown using low rates, fly the aircraft until you are familiar with its characteristics prior to trying high rates. Make sure the aircraft is flying at a decent altitude and speed prior to using high rates, as the aircraft will be sensitive to control inputs with the larger control surface movements.

	High Rate	Low Rate
<b>Elevator</b>	18mm up / down	12mm up / down
<b>Rudder</b>	24mm left / right	18mm left / right
<b>Aileron</b>	16mm up / down	10mm up / down

## Control horn and servo arm settings



1. The table shows the factory settings for the control horns and servo arms. Fly the aircraft at the factory settings before making changes.

2. After flying, you may choose to adjust the linkage positions for the desired control response.

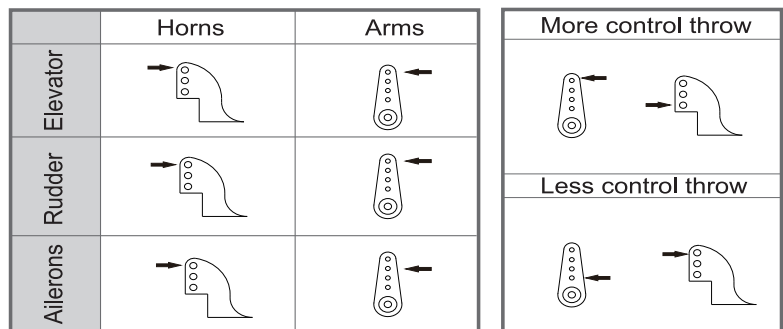

## « — Finding the center of gravity

Finding the correct center of gravity is critical in ensuring that the aircraft performs in a stable and responsive manner. Please adjust the weight distribution so the aircraft balances in the range stated on the diagram.

- Depending on the capacity and weight of your chosen flight batteries, move the battery forward or backward to adjust the center of gravity.
- If you cannot obtain the recommended CG by moving the battery to a suitable location, you can also install a counterweight to achieve correct CG. However, with the recommended battery size, a counterweight is not required. We recommend flying without unnecessary counterweight.

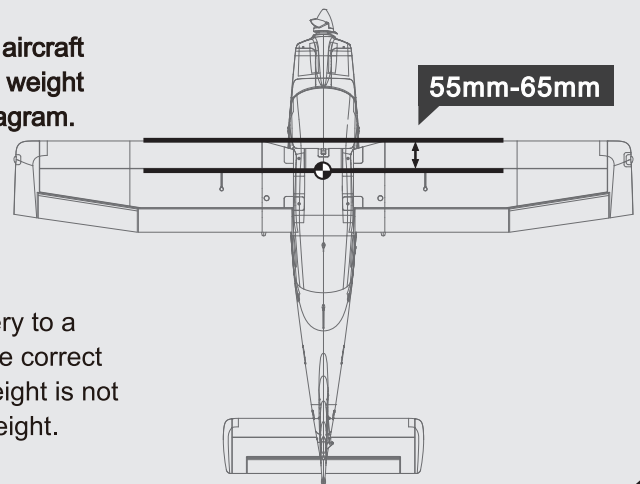

## « — Before flying the model

### Find a suitable flying site

Find a flying site clear of buildings, trees, power lines and other obstructions. Until you know how much area will be required and have mastered flying your plane in confined spaces, choose a site which is at least the size of two to three football fields - a flying field specifically for R/C planes is best. Never fly near people - especially children, who can wander unpredictably.

### Performing a range check

A radio range check should be performed prior to the first flight of the day. This test may assist you in detecting electronic problems that may lead to a loss of control- problems such as low transmitter batteries, defective or damaged radio components or radio interference. This usually requires an assistant and should be done at the flying site.

Always turn your transmitter on first. Install a fully charged battery in the battery bay, then connect it to the ESC. In this process, make sure that the throttle cut functionality is on, and that the throttle stick is secured in its lowest position- otherwise, the propeller/fan will engage and possibly cause bodily harm.

**Note:** Please refer to your transmitter manual that came with your radio control system to perform a ground range check. If the controls are not working correctly or if anything seems wrong, do not fly the model until you correct the problem. Make certain all the servo wires are securely connected to the receiver and the transmitter batteries have a good connection.

## Before flying the model

### Monitor your flight time

Monitor and limit your flight time using a timer (such as a stopwatch or on the transmitter, if available). As modern Lithium Polymer batteries are not designed to discharge completely, when the battery runs low, the ESC will lower then completely cut the power to the motors to protect the battery. Often (but not always) power can be briefly restored after the motor cuts off by holding the throttle stick all the way down for a few seconds. To avoid an unexpected dead-stick landing on your first flight, set your timer to a conservative 4 minutes. When your alarm sounds you should land right away.

## Flying course

### Take off

Point the aircraft into the wind while slowly applying power until the aircraft starts to track straight, use the rudder when necessary. When the aircraft reaches takeoff speed, ease back on the elevator stick until the aircraft is climbing at a constant rate without decelerating. Climbing at too steep of an angle at the relatively low speeds of a takeoff-climb may result in an aerodynamic stall.

### Flying

Always choose a wide-open space for flying your plane. It is ideal for you to fly at a sanctioned flying field. If you are not flying at an approved site always avoid flying near houses, trees, wires and buildings. You should also be careful to avoid flying in areas where there are many people, such as busy parks, schoolyards, or soccer fields. Consult laws and ordinances before choosing a location to fly your aircraft. After takeoff, gain some altitude. Climb to a safe height before trying technical manoeuvres.

### Landing

Land the aircraft when you start to feel sluggish motor response. If using a transmitter with a timer, set the timer so you have enough flight time to make several landing approaches. The model's three point landing gear allows the model to land on hard surfaces. Align model directly into the wind and fly down to the ground. Fly the airplane down to the ground using 1/4-1/3 throttle to keep enough energy for proper flare. Before the model touches down, always fully decrease the throttle to avoid damaging the propeller or other components. The key to a great landing is to manage the power and elevator all the way to the ground and set down lightly on the main landing gear. With some practice, you will be able to set the aircraft gently on its main gear and hold it that way until the speed reduces enough where the nose wheel (tricycle landing gear aircraft) or tail wheel (tail draggers) settles onto the ground.

### Maintenance

Repairs to the foam should be made with foam safe adhesives such as hot glue, foam safe CA, and 5min epoxy. When parts are not repairable, see the spare parts list for ordering by item number. Always check to make sure all screws on the aircraft are tightened. Pay special attention to make sure the spinner is firmly in place before every flight.

## « Troubleshooting

<b>Problem</b>	<b>Possible Cause</b>	<b>Solution</b>
Aircraft will not respond to the throttle but responds to other controls.	<ul style="list-style-type: none"> <li>• ESC is not armed.</li> <li>• Throttle channel is reversed.</li> </ul>	<ul style="list-style-type: none"> <li>• Lower throttle stick and throttle trim to lowest settings.</li> <li>• Reverse throttle channel on transmitter.</li> </ul>
Excessive vibration or propeller noise.	<ul style="list-style-type: none"> <li>• Damaged spinner, propeller, motor or motor mount.</li> <li>• Loose propeller and spinner parts.</li> <li>• Propeller installed backwards.</li> </ul>	<ul style="list-style-type: none"> <li>• Replace damaged parts.</li> <li>• Tighten parts for propeller adapter, propeller and spinner.</li> <li>• Remove and install propeller correctly.</li> </ul>
Reduced flight time or aircraft underpowered.	<ul style="list-style-type: none"> <li>• Flight battery charge is low.</li> <li>• Propeller installed backward.</li> <li>• Flight battery damaged.</li> </ul>	<ul style="list-style-type: none"> <li>• Completely recharge flight battery.</li> <li>• Replace flight battery and follow flight battery instructions.</li> </ul>
Control surfaces unresponsive or sluggish.	<ul style="list-style-type: none"> <li>• Control surface, control horn, linkage or servo damage.</li> <li>• Wire damaged or connections loose.</li> </ul>	<ul style="list-style-type: none"> <li>• Replace or repair damaged parts and adjust controls.</li> <li>• Do a check of connections for loose wiring.</li> </ul>
Controls reversed.	<ul style="list-style-type: none"> <li>• Channels are reversed in the transmitter.</li> </ul>	<ul style="list-style-type: none"> <li>• Do the control direction test and adjust controls for aircraft and transmitter.</li> </ul>
Motor loses power Motor power pulses then motor loses power.	<ul style="list-style-type: none"> <li>• Damage to motor, or battery.</li> <li>• Loss of power to aircraft.</li> <li>• ESC uses default soft Low Voltage Cutoff(LVC).</li> </ul>	<ul style="list-style-type: none"> <li>• Do a check of batteries, transmitter, receiver, ESC, motor and wiring for damage(replace as needed).</li> <li>• Land aircraft immediately and recharge flight battery.</li> </ul>

## « Spare parts list

AHAP101	Fuselage	AHAP117	Tire set
AHAP102	Main Wing	AHAP118	Float set
AHAP103	Horizontal Stabilizer	AHPROP011	Propeller
AHAP104	Cowl	AHMount005	Motor Mount
AHAP105	Battery Cover	AHShaft005	Motor Shaft
AHAP106	Spinner	AHBoard010	Motor Board
AHAP107	R clasp	AHKV850	3536-KV850
AHAP108	Sticker	AHESC30A	30A ESC
AHAP109	Linkage Rods	AH9G54P	9g gear servo 54 degree
AHAP110	Screws set	AH9GPW	9g Servo (with waterproof function)
AHAP111	Pipe	AH9GP	9g Servo
AHAP112	Control Horns		
AHAP113	Supporting Struts		
AHAP114	Front Landing Gear Set		
AHAP115	Rear Landing Gear Set		
AHAP116	Landing Gear Insert		

## 重要提示：

1. 在组装、调整及飞行前请务必认真阅读产品说明书以熟知产品的特性。请严格按照说明书提示进行飞机的组装、调整及飞行。
2. 模型不是玩具，具有一定的危险性，操作者需要具备一定的飞行经验，初学者请在专业人士指导下操作。
3. 禁止十四岁以下儿童在任何情况下操作、飞行。

## 警告

- ★作为用户，您对本产品的安全操作和维护负全部责任。请始终严格遵照产品指导说明及安全警告操作本产品及其相关配置（例如遥控器、充电器、电池等）。
- ★本产品由无线电遥控器控制，在飞行过程中，可能会受到外界强信号源干扰而导致失控，甚至坠机，因此在飞行过程中务必始终与飞机保持一定的安全距离，避免意外碰撞、受伤。
- ★请勿随意暴露置放模型飞机的电子产品，尤其是电池，存放时请务必保证周围三米之内无易燃易爆物体。
- ★在任何情况下，都务必保证油门杆处于起始位、发射机处于通电状态时，才能连接模型飞机内部的动力电池。
- ★在任何情况下，都不要尝试用手去回收飞行中的模型飞机，必须要等模型飞机降落停稳以后，再进行回收。
- ★请勿在公路、人群、高压线密集区、机场附近及其它法律法规明确禁止飞行的场合飞行。
- ★请勿在雷雨、大风、大雪或者其它恶劣气象环境下飞行。
- ★请勿将相关化工类产品、零部件、电子部件等置于儿童可触及的范围。
- ★请勿将本产品尤其是未经特别设计和保护的电子件暴露于潮湿的环境中，以免造成损坏。
- ★请勿将本品任意处置于口中，以免造成人身伤亡。
- ★请勿在发射机电池低电量的情况下操纵模型飞机。
- ★请勿在配件未充分冷却的情况下触碰或移动。
- ★请勿使用化学制剂擦拭清洁本产品。
- ★务必保证飞机在整个操作过程中始终在视线范围和遥控控制距离内。
- ★务必保证在拆卸飞机之前移除电池。
- ★务必保证所使用的电池是满电状态。
- ★务必保证所使用的所有线束完好无损。

## 飞行前准备

1. 开箱检查包装内物品是否有损坏或遗漏。
2. 通读此飞机说明书以及其相关配置说明书（如遥控器、电池和充电器）。
3. 确保遥控器和使用的电池都是满电状态（请严格遵从配件原厂家说明书）。
4. 遥控器设置（请严格遵从遥控器厂家的说明书）。
5. 严格遵从本说明书指导组装飞机，确保螺丝、卡扣、夹头、插销等紧固件全部安装到位，舵角摇臂连接可靠。（暂不安装螺旋桨）。
6. 安装满电状态的电池，并通过挪动电池在电池舱里的前后位置，调整飞机重心（CG）至说明书推荐位置。
7. 通电测试确保所有的操纵钢丝活动自如。
8. 通电测试确保所有的舵面正确响应遥控器输入指令。
9. 根据所需调整舵面行程（首飞推荐使用出厂设置行程）。
10. 桨机安装螺旋桨，确保螺旋桨组件安装到位，且转动方向正确。
11. 寻找一个安全空旷远离建筑和人群的场地，根据场地实际情况，做具体飞行计划。

## 飞机简介

Arrows Hobby, 探索, 永无止境。1450mm 级别上单翼教练机——领航者 (Tecnam-2010), 重磅来袭。

领航者是一款专为初学者研制的教练机。

它首先拥有初学者的原始需求: 易安装、易操控。易安装: 快拆快装结构, 玩家只需拧紧几颗螺丝即可起飞 (装饰件除外), 拆掉几颗螺丝即可收箱, 给外出飞行、运输和储藏带来极大便利。易操控: 方向舵和前轮转向分开各自独立, 便利飞行姿态调平和地面直线起降; 前三点式起落架布局滑跑指向性更优; 低翼载荷、高升阻比, 使玩家即使在低速飞行时也能够操控自如; 带有维翼飞行控制系统, 有效解决各种倾角问题, 最大限度地“容错”, 给新手畅飞的底气。

它其次也满足初学者的更高需求: 动力和进阶功能。动力: 大厂贴牌制作的高品质 3536-850KV 电机和 30A 电调 (厂家推荐电池 11.1V 2200MAH 25C), 配合高效 11\*7 两叶螺旋桨给飞行提供源源不断的动力, 在油门分配得当的情况下, 飞行时间可长达 15 分钟。进阶功能: 配备浮筒起落架, 便于玩家进阶练习水面起降。一架飞机, 双重乐趣, 在有限的预算里实现无限的可能。

此外, 坚固耐用的塑料斜撑, 有效增加主翼强度和负载; 卡扣式座舱, 给飞行免除后顾之忧; 精选春天绿色涂装, 显色性好, 辨识度高。

Arrows Hobby EPO 泡沫教练机——领航者, 给你一个领略世界的全新窗口。

### 特征:

- 电子配置: 3536-850KV 电机, 30A 电调, 9g 数码舵机
- 功能性襟翼, 一体平尾, 可实现优越的低速操控性能
- 出厂配备两套起落架套装, 可实现水陆起降
- 可实现五米短距离起降
- 大尺寸电池舱, 便利玩家自行升级
- 五金抗震起落架
- 高亮夜航灯
- 卡扣式座舱
- 螺丝组装结构 (装饰件除外)
- EPO 泡沫材料

## 目录

飞行前准备 .....	13
飞机简介 .....	14
目录 .....	14
产品包装清单 .....	14
组装过程 .....	15
电池安装 .....	18
接收机连接示意图 .....	18
重心 .....	19
重要产品相关信息 .....	19
电调说明 .....	19
遥控器设置 .....	19
舵面测试 .....	20
舵角和舵机摇臂安装 .....	21
舵面行程 .....	21
故障检修指导 .....	22
配件列表 .....	22

## 产品基本参数

翼展	1450mm (57.1in)
机身长	1110mm (43.7in)
飞行重量	~ 1280g
电机	3536-KV850
翼载荷	42.7g/dm <sup>2</sup> (0.09oz/in <sup>2</sup> )
翼面积	30dm <sup>2</sup> (464sq.in)
电调	30A
舵机	9g Servo x 7
推荐电池	11.1V 2200mAh 25C

**! 注意:** 此处各项参数, 均是使用本公司配件测试得出, 如果使用他厂配件, 会有所差异。使用他厂配件时所产生的问题, 我司将无法给予技术支持。

## 产品包装清单

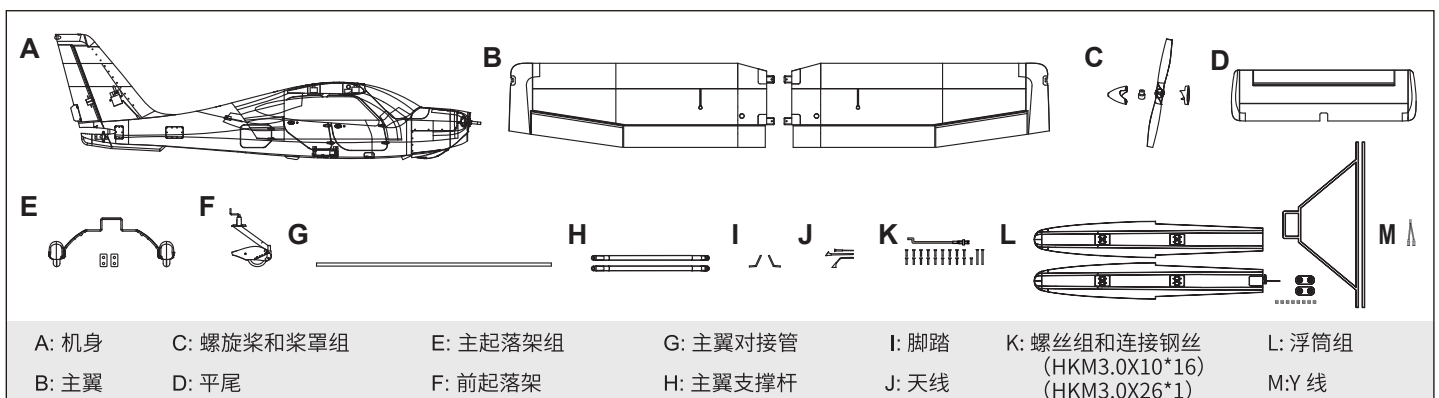

## 主翼安装

1. 将主翼对接管安装至机身对应槽位。
2. 将左右主翼安装至对接管，往机身方向合拢主翼。

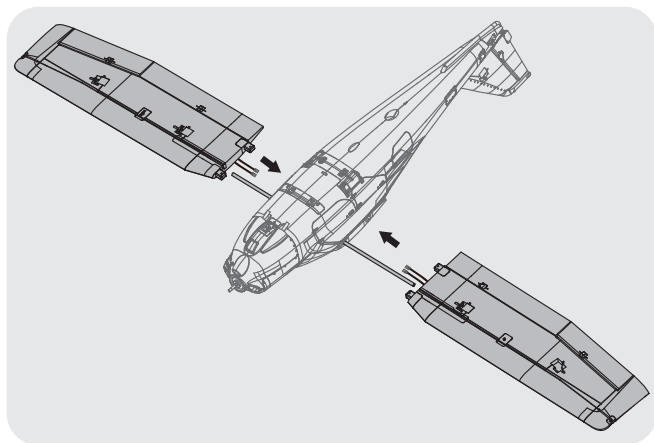

3. 将副翼舵机线、襟翼舵机线以及灯线分别穿入机身，并用“Y”线连接。
4. 如图所示，使用所附螺丝固定主翼至机身，注意不要过锁螺丝。

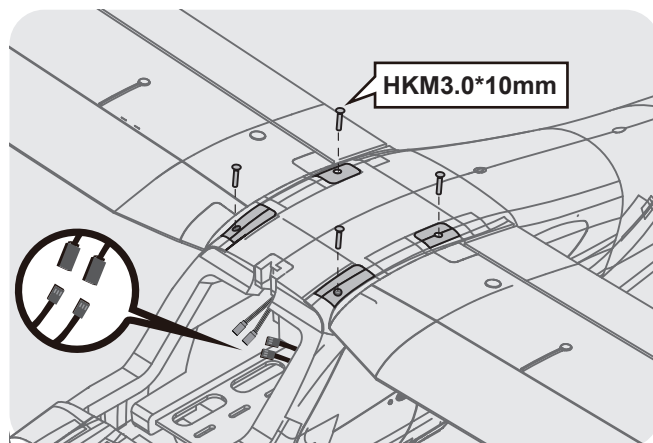

5. 将支撑杆两端分别安装至图示机身与主翼位置，确保两端没有反装。
6. 使用“R”型扣固定支撑杆。

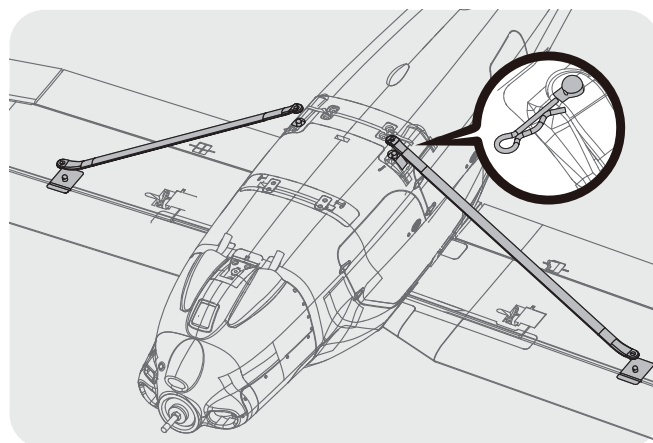

## 平尾安装

1. 如图所示，将平尾安装至机身尾部槽位，保持平尾舵角朝下。

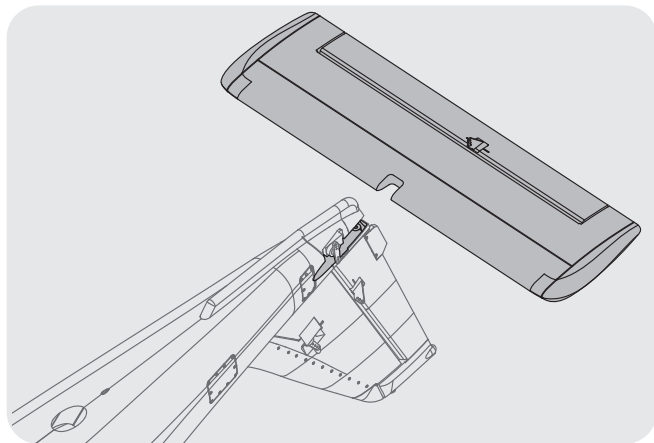

2. 取下方向舵夹头，按图将方向舵调整到最大角度，使用所附螺丝固定平尾，注意不要过锁螺丝。

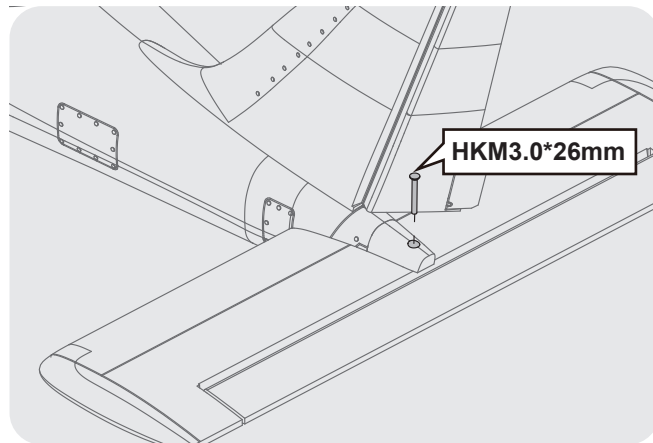

### 连接钢丝安装

1. 如图所示，保持舵机回中状态，将连接钢丝安装至平尾舵机摇臂。

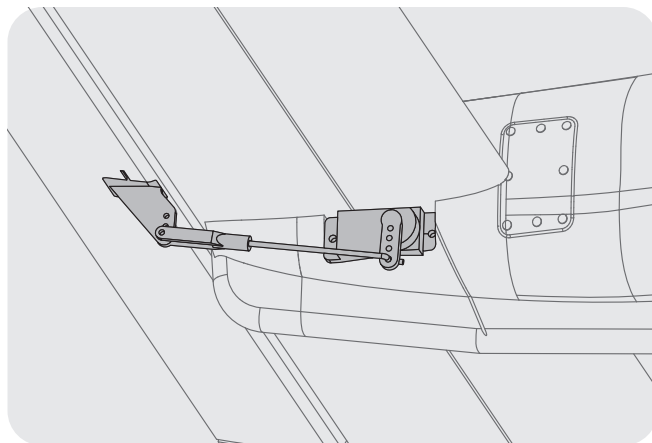

### 起落架安装

1. 将主起落架安装至机身底部图示槽位，注意轮罩朝向，不要反装。

2. 使用垫片和所附螺丝固定主起落架。

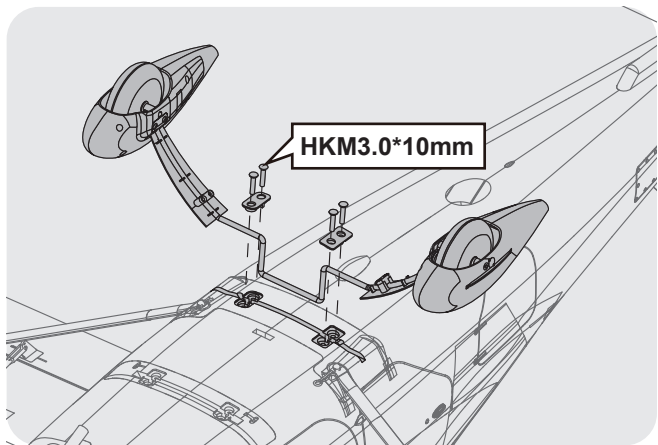

3. 将前起落架安装至机身底部图示槽位，确保钢丝装入转向摇臂孔。

4. 使用所附螺丝固定前起落架。

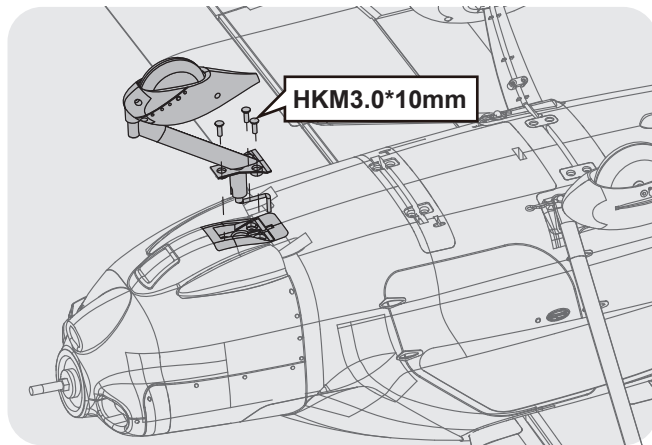

### 脚踏安装

1. 在图示位置打胶，将脚踏安装至机身底部槽位。

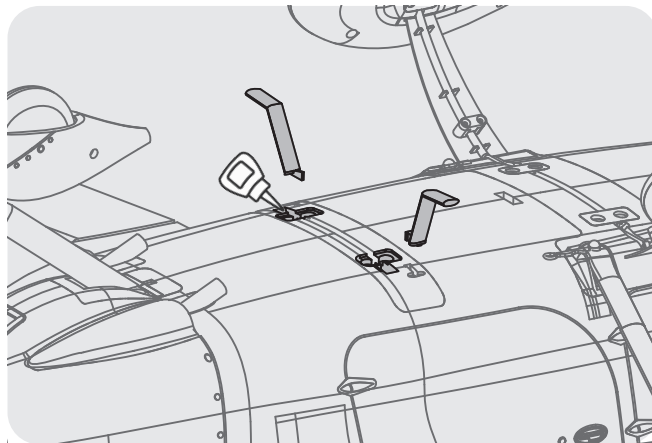

### 天线安装

1.如图所示，在机身顶部和底部槽位打胶，将天线分别安装至相应槽位。

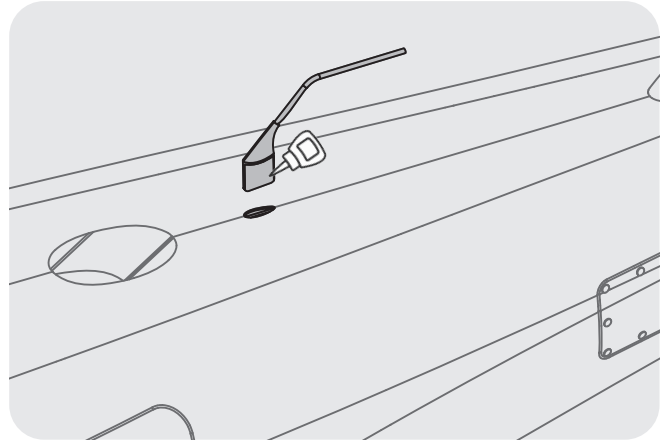
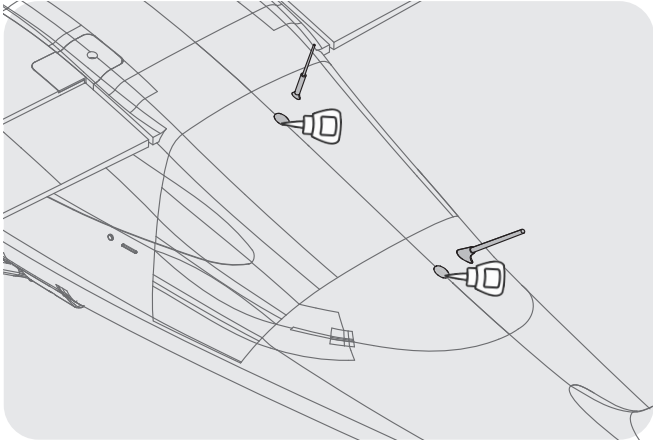

### 螺旋桨和桨罩组安装

1.如图所示，依序安装螺旋桨和桨罩组，注意不要过锁螺丝。

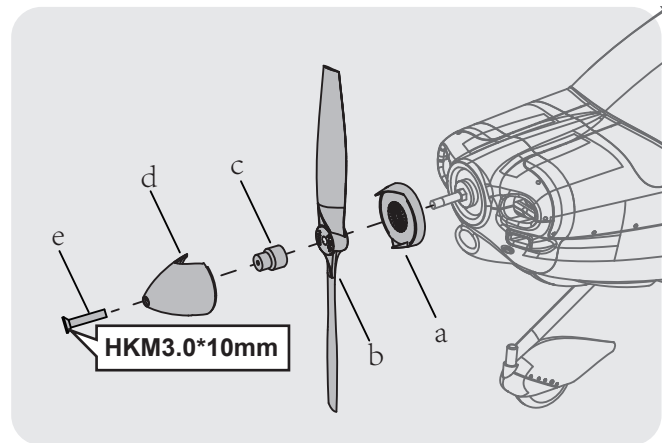

### 浮筒安装

1.如图所示，将浮筒支撑杆安装至图示塑胶件部分，用螺丝固定支撑杆。

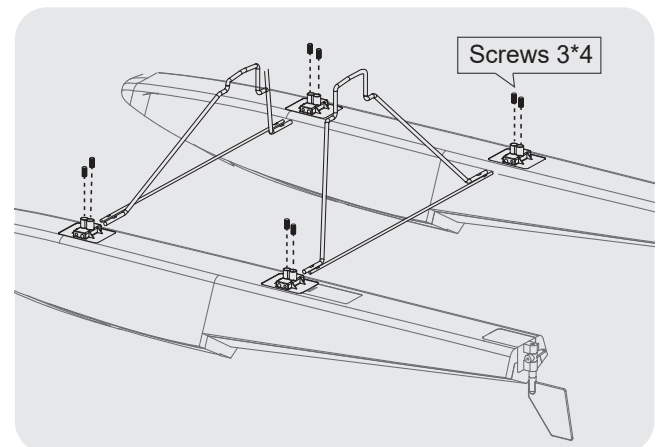

## 《—— 组装过程

2.如图所示，将装上支撑杆的浮筒组安装至机身底部，使用所附螺丝和塑胶压片固定。  
注意：确保插牢浮筒和机身的对接插头。

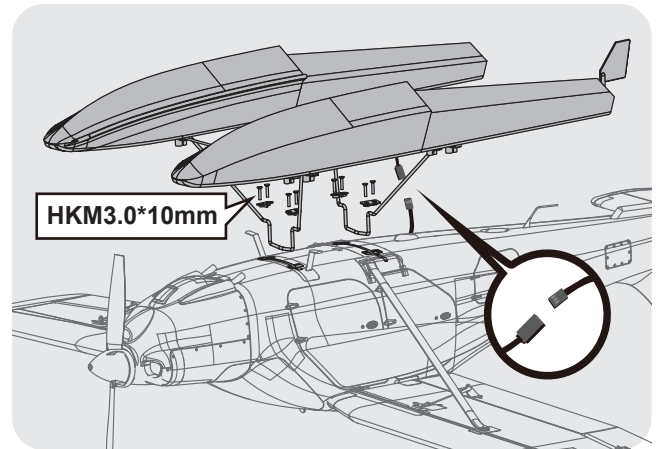

## 《—— 电池安装

如图所示，安装厂家推荐型号电池至电池舱，使用所附魔术带或魔术贴固定。

### 注意：

1. 电池与电调连接前，务必确定油门杆处于低位。
2. 启动油门前，务必确定没有任何人或物体处于螺旋桨的转动直径以内。
3. 由于不同电池厂家生产的电池重量有轻微差异，需要调整电池在舱内的前后位置来平衡飞机的重心位置。

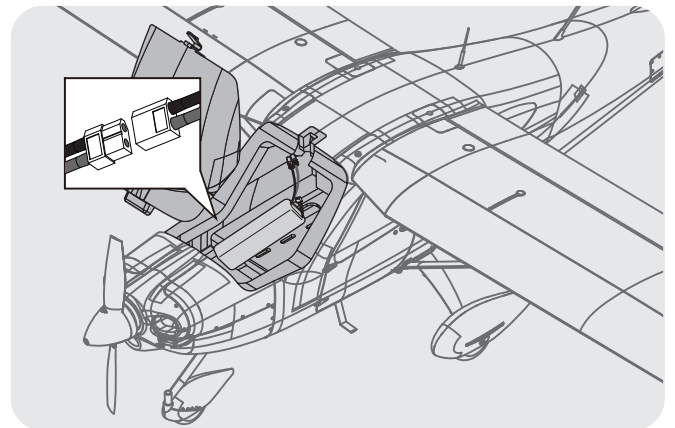

## 《—— 接收机连接示意图

以 Futaba 遥控器为例，请按照图示顺序一一连接接收机通道，其他通道可接入襟翼信号线或 LED 灯信号线，随后妥善固定接收机。

		Receiver
副翼	1	Channel-1 —Aile
平尾	2	Channel-2 —Elev
油门	3	Channel-3 —Thro
垂尾	4	Channel-4 —Rudd
起落架	5	Channel-5 —Gear
其他通道	6	Channel-6 —Spare

本产品的重心在机翼前缘向后 55-65mm 的位置。玩家需要通过移动电池在电池舱里的前后位置或者使用配重块来调整重心。请务必确保，在调整飞机重心的时候，飞机处于组装完毕待飞的状态。

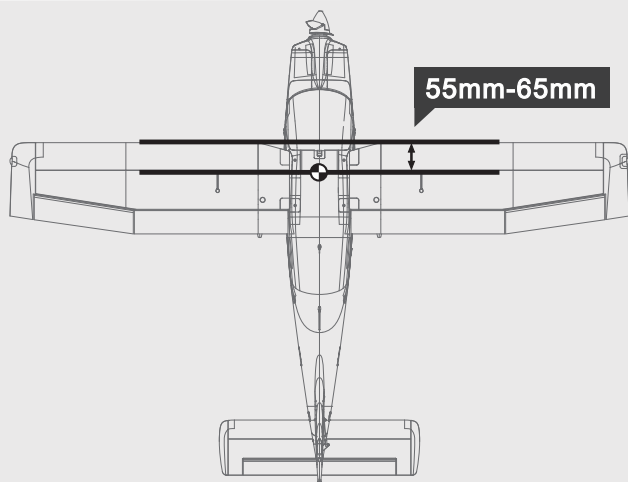

## 重要产品相关信息

1. 本产品随附的电调处在安全启动模式。安全启动模式，意即如果电机、电池已连接至电调，但油门杆不在低油门位置或关闭位置，电机不会启动，只有将油门杆移至低油门位置或关闭位置，电机才会启动。油门杆移至低油门位置或关闭位置时，电机将发出一系列哔声。几声相同的哔声表示电调已检测到电池。哔声的数量等于电池的节数。此时，电机已准备就绪，并将随着油门移动开始启动。
2. 电机和电调已预连接，需要观察电机转动方向是否正确，如方向不正确，只需换插三条电机与电调连接线中的任意两条，即可改变电机转动方向。
3. 电机具有刹车设置（可选项）。由于电调是刹车关闭状态，我们推荐电机也保持刹车关闭状态。此外，请注意，当油门杆处在全油门位置上时，如果将电机、电池连接到电调，则可能会意外打开刹车。如要关闭刹车，需将油门杆移至全油门位置，并插上电机电池，电机此时会发出一声哔响，再将油门杆移至低油门位置或关闭位置，则电机已准备就绪，且刹车将被关闭。
4. 电池的选择和安装。我们推荐使用 11.1V 2200mAh 25C 锂电池。如果使用其他电池，电池的容量不能低于推荐电池容量，且电池的尺寸和重量应与推荐电池相同，以保证适配机身电池舱，且不会显著改变重心。

## 电调说明

**注意：**为了让电调适应你的遥控器油门行程，在首次使用本电调或更换其他遥控器使用时，均应重新设定油门行程。

油门行程设定说明：

1. 开启遥控器，将油门打到最高点；
2. 将电调接上电池，等待 2 秒；
3. “哔 - 哔 -” 油门最高点，确认声音；
4. 将油门推到最低等待 1 秒；
5. N 声短鸣音表示锂电节数；
6. “哔 -” 油门最低点，确认声音；
7. 系统准备就绪可以起飞。

正常使用开机过程说明：

1. 开启遥控器，将油门打到最低点；
2. 电调接上电池，鸣叫提示音符“123”，表示上电正常；
3. 发出 N 声短鸣音，表示锂电池节数；
4. 自检 OK，发出长鸣音“哔——”系统准备就绪；
5. 推油门可随时起飞。

## 遥控器设置

请参考遥控器原厂家说明书。

## 舵面测试

在计划飞行之前，需要使用遥控器测试每个舵面的工作情况，确保摇杆动作与各个舵面动作的对应关系如下图所示：

**注意：**在舵面调试中，请务必将油门摇置于最低位，并将桨拆下，以免电机意外启动发生事故。

### 副翼

副翼摇杆  
向左运动

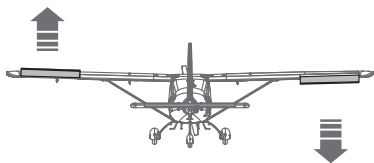
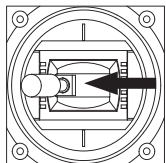

副翼摇杆  
向右运动

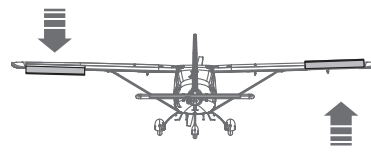
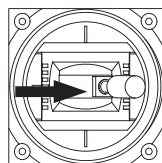

### 升降舵

升降摇杆  
向上运动

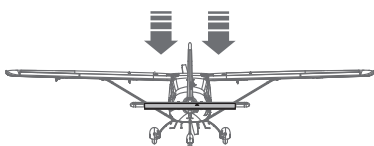
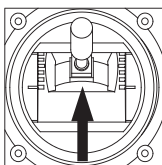

升降摇杆  
向下运动

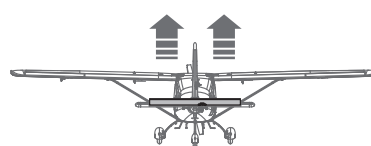
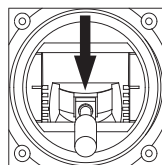

### 方向舵

方向摇杆  
向左运动

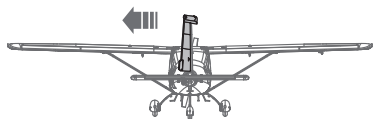
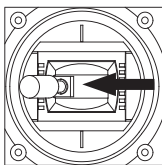



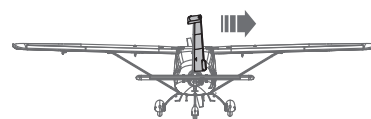
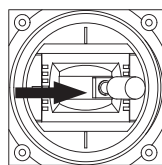



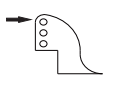

方向摇杆  
向右运动

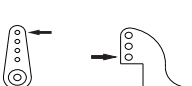
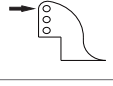

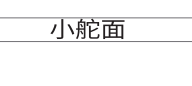
## 舵角和舵机摇臂安装

图示是出厂设置，首飞建议直接使用出厂设置，完成首飞以后，根据个人情况以及对模型飞机的熟知程度自行调整。

	舵角	摇臂	大舵面
平尾			
垂尾			
副翼			

## 舵面行程

本产品舵面行程参数如右图所示：

请注意，舵量越大，模型飞机的动作响应越快，动作幅度越大。首飞建议使用小舵量。然后根据个人情况以及对模型飞机的熟知程度调整舵量。

	大	小
升降舵	18mm 上 / 下	12mm 上 / 下
方向舵	24mm 左 / 右	18mm 左 / 右
副翼舵	16mm 上 / 下	10mm 上 / 下

## 故障检修指导

问题	问题原因	解决方式
油门推杆无响应，但舵机有响应	<ul style="list-style-type: none"> <li>——电调未连接电机</li> <li>——油门通道反向</li> </ul>	<ul style="list-style-type: none"> <li>——降低油门推杆和油门微调设定</li> <li>——反过来重新装油门通道</li> </ul>
桨的噪音过大或者震动过大	<ul style="list-style-type: none"> <li>——桨罩、桨、电机、电机架坏了</li> <li>——桨或者桨罩的小部件松动了</li> <li>——桨装反了</li> </ul>	<ul style="list-style-type: none"> <li>——更换损坏的配件</li> <li>——把桨、桨夹和桨罩的小部件拧紧</li> <li>——反过来重新装桨</li> </ul>
飞行时间变短，飞机无力	<ul style="list-style-type: none"> <li>——电池电量低</li> <li>——桨装反了</li> <li>——电池坏了</li> </ul>	<ul style="list-style-type: none"> <li>——重新给电池充电</li> <li>——依照电池说明书更换新的电池</li> </ul>
飞舵面不动，或者动作响应较慢	<ul style="list-style-type: none"> <li>——舵面、舵角、连接杆、舵机坏了</li> <li>——连接线坏了或者接头松了</li> </ul>	<ul style="list-style-type: none"> <li>——更换或者维修坏了的配件</li> <li>——检查所有连接线，确保所有接头无松动现象</li> </ul>
舵面反向	<ul style="list-style-type: none"> <li>——遥控器发射机通道反向</li> </ul>	<ul style="list-style-type: none"> <li>——检查通道控制（舵面）方向，调试飞机舵面和遥控器的舵面控制杆</li> </ul>
电机无力	<ul style="list-style-type: none"> <li>——电机或电池坏了</li> <li>——电调用了不合适的低压保护装置</li> </ul>	<ul style="list-style-type: none"> <li>——检查电池、发射机、接收机、电调、电机是否有损坏（如有，请及时更换）</li> <li>——立刻操控飞机降落，重新给电池充电</li> </ul>

## 配件列表

AHAP101	机身	AHAP117	轮胎组
AHAP102	主翼	AHAP118	浮筒组
AHAP103	平尾	AHPROP011	桨，11*7 两叶
AHAP104	机头罩	AHMount005	电机架
AHAP105	电池盖	AHShaft005	电机轴
AHAP106	桨罩	AHBoard010	电机板
AHAP107	R 卡扣	AHKV850	3536-KV850 电机
AHAP108	贴纸	AHESC30A	30A 电调
AHAP109	操纵钢丝	AH9G54P	9g 塑胶 54 度正向舵机
AHAP110	螺丝组	AH9GPW	9 克舵机（带防水功能）
AHAP111	对接管	AH9GP	9 克舵机
AHAP112	舵面摇臂		
AHAP113	支撑杆		
AHAP114	前起落架组		
AHAP115	后起落架组		
AHAP116	起落架锁扣插片		



**MADE IN CHINA**